

TRIGEN INTERTAN Technique utilizing the Gold Instrument Set



TRIGEN[◇] INTERTAN[◇] Intertrochanteric Antegrade Nail

Surgical Technique

Table of contents

Indications	2
TRIGEN INTERTAN case examples	3
Design features	4
Implant specifications	5
Surgical technique	6
Implant selection	6
Patient positioning	6
Opening the proximal femur	8
Incision and entry point	8
Entry portal acquisition	9
Intramedullary reaming	12
Fracture reduction	12
Implant measurement (long nails)	13
Preparing the canal	13
Nail insertion	15
Nail assembly	15
Insertion	16
Nail anteversion	16
Insertion depth	17
Proximal locking overview	18
Proximal locking	20
Lag Screw Drill Sleeve insertion	20
Lag Screw Guide Pin insertion	20
Lag Screw measurement	21
Integrated Interlocking Screw insertion	23
No compression	25
With compression	26
Cannulated Set Screw	27
Subtrochanteric Lag Screw insertion	29
No compression	29
With compression	30
Cannulated Set Screw	31
Distal locking	33
Short nail	33
Long nail	33
Nail Cap insertion: optional	34
Closure	34
Implant removal	36
Catalog information	39

Nota Bene

The technique description herein is made available to the healthcare professional to illustrate the author's suggested treatment for the uncomplicated procedure. In the final analysis, the preferred treatment is that which addresses the needs of the specific patient.

Indications

The TRIGEN® INTERTAN® nail is indicated for fractures of the femur including simple shaft fractures, comminuted shaft fractures, spiral shaft fractures, long oblique shaft fractures and segmental shaft fractures; subtrochanteric fractures; intertrochanteric fractures; ipsilateral femoral shaft/neck fractures; intracapsular fractures; nonunions and malunions; polytrauma and multiple fractures; prophylactic nailing of impending pathologic fractures; reconstruction, following tumor resection and grafting; bone lengthening and shortening.

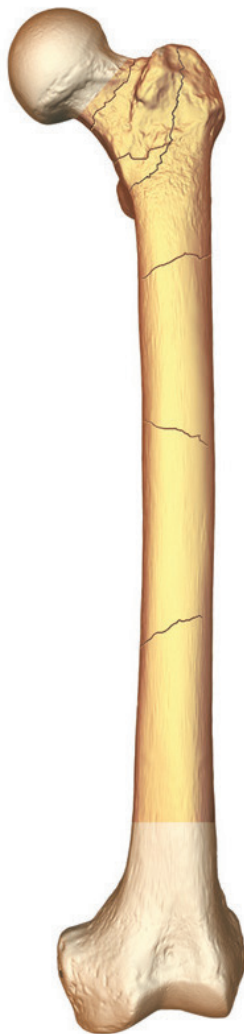

TRIGEN[®] INTERTAN[®] system case examples

Case 1



Preoperative AP



Postoperative AP



Postoperative Lateral

Case 2



Preoperative AP



Postoperative AP



Postoperative Lateral

Design features

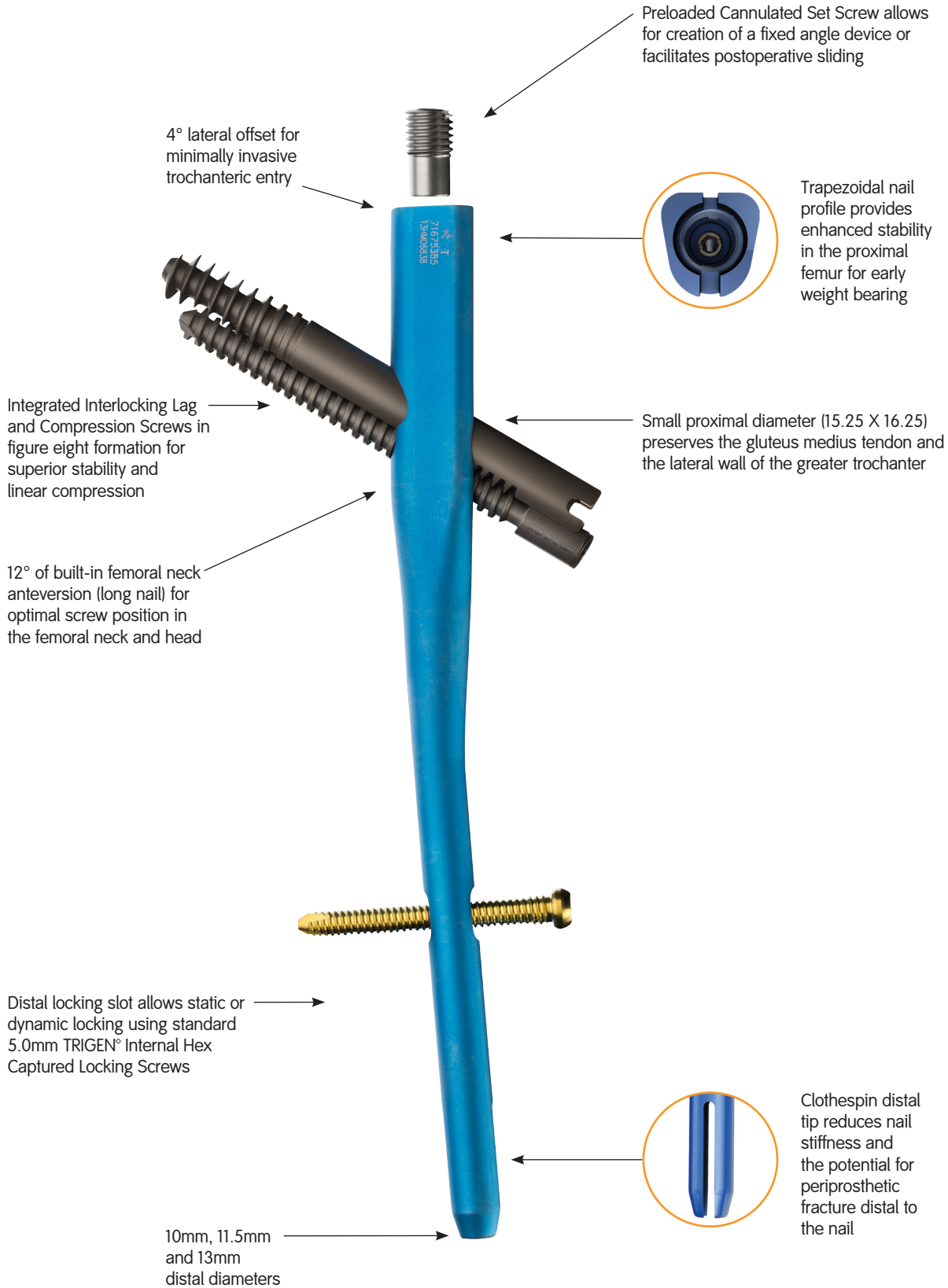

Implant specifications

TRIGEN[®] INTERTAN[®] nail (long)

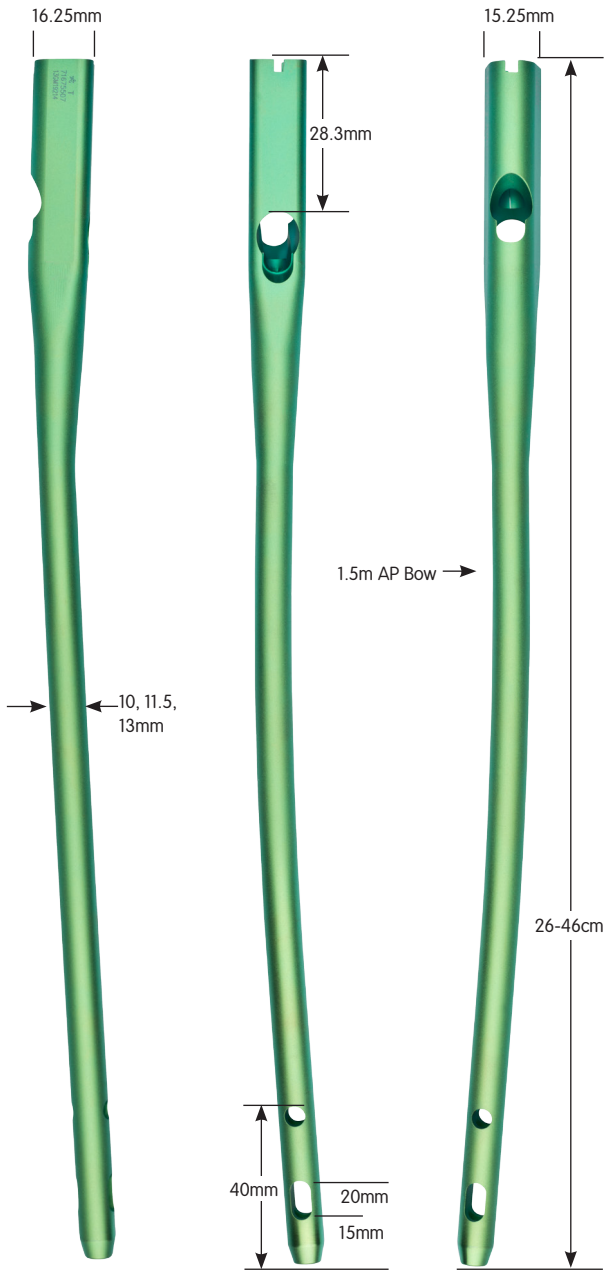

TRIGEN INTERTAN nail (short)

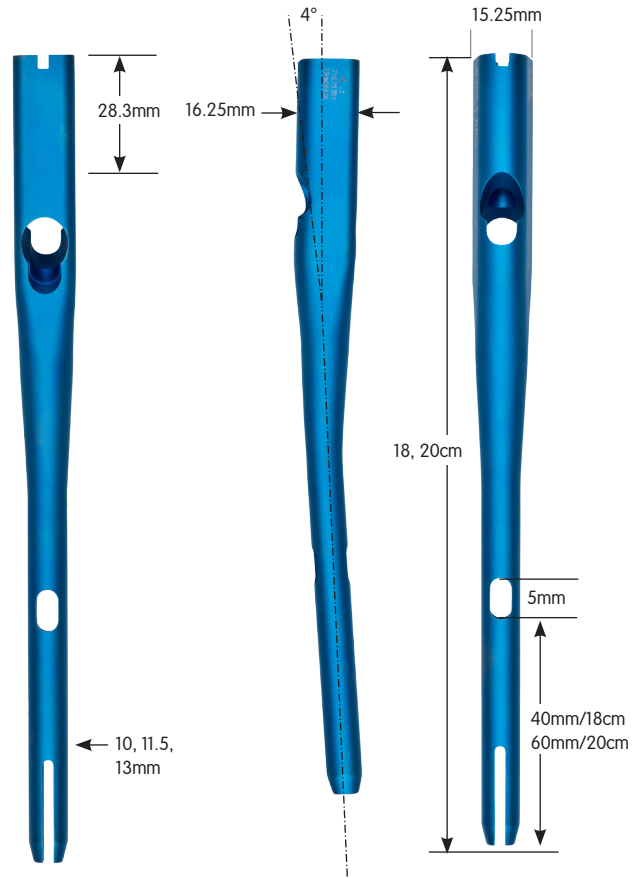

TRIGEN INTERTAN lag and compression screws

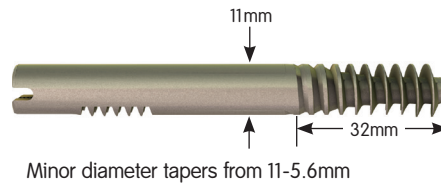

TRIGEN INTERTAN subtrochanteric lag screw



Minor diameter tapers from 11-5.6mm
Subtrochanteric Lag Screw 70-125mm

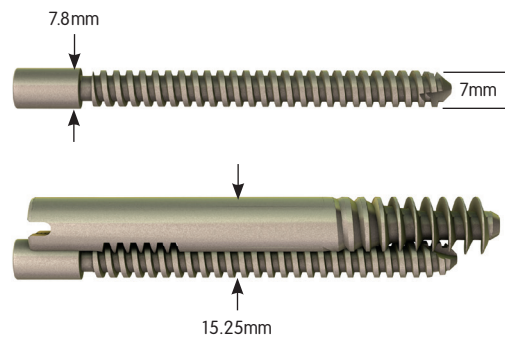

Integrated Interlocking Screws (sold together) 70-125mm

Note These views are not to scale and should be used as a pictorial representation only.

Surgical technique

Implant selection

The TRIGEN® INTERTAN® Nail Preoperative Template Set (7167-4200) may be used to assist with preoperative implant selection. Nail size, screw length and femoral neck angle may be determined.

Note As template magnification levels are set at 117%, all measurements are estimates of true size. All measurements must be verified intraoperatively.

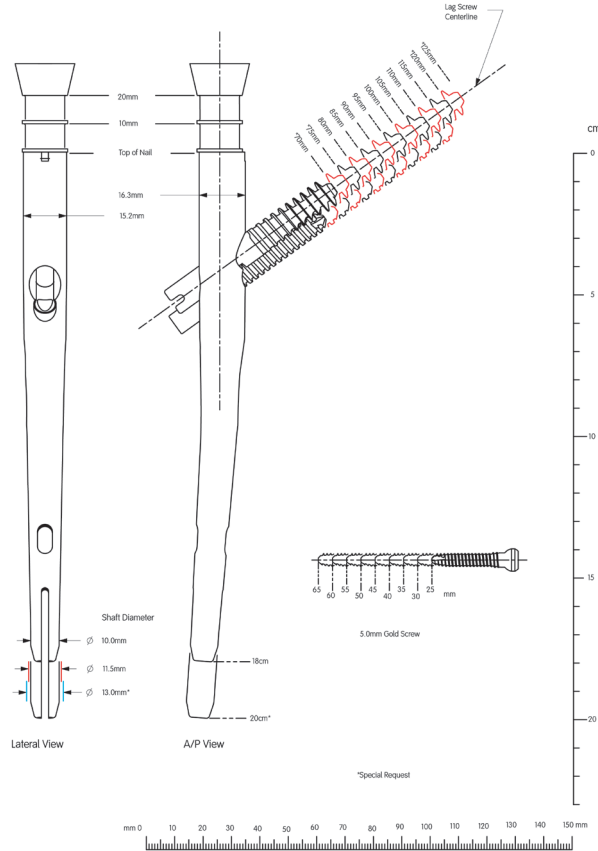

TRIGEN INTERTAN Nail Preoperative Template Set
Set No. 7167-4200

Patient positioning

Place the patient in the supine or lateral decubitus position on a fracture table according to surgeon preference and/or fracture pattern. The foot of the affected limb is placed in a foot holder or a skeletal traction pin is inserted through the calcaneus to achieve traction. The unaffected limb is extended down and away from the affected limb or is placed up in a leg holder.

The torso may be abducted 10°–15° to allow for clear access to the intramedullary canal. Check the affected limb for length and rotation by comparison to the unaffected limb. Rotate the C-Arm to ensure optimal AP and lateral visualization of the proximal femur.

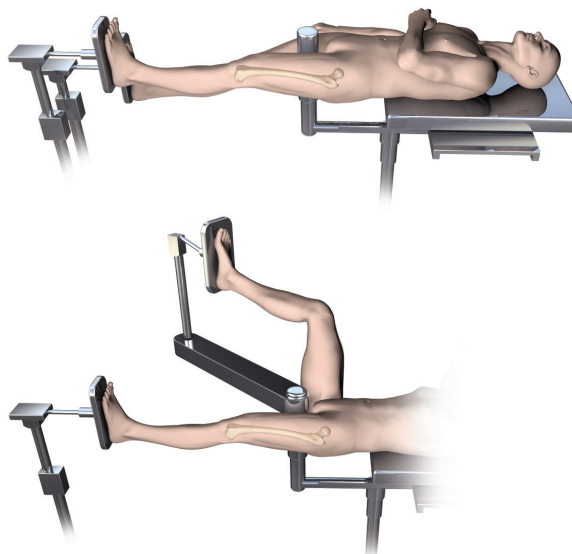

Note If using a radiolucent table, a distraction device may be helpful in reducing the fracture.

Instruments for opening the proximal femur



Guide Pin 3.2mm x 343mm
Cat. No. 7163-1436



Mini Connector
Cat. No. 7163-1186

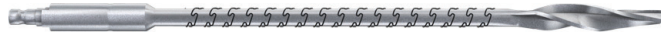

12.5mm Entry Reamer
Cat. No. 7163-1116



Honeycomb
Cat. No. 7167-4075



Entry Portal Tube
Cat. No. 7167-4060



Entry Portal Handle
Cat. No. 7167-4092



16mm Channel Reamer*
Cat. No. 7167-4062

* Also available: 17mm Channel Reamer (7167-4063)

Opening the proximal femur

Incision and entry point

Assemble the Honeycomb (7167-4075), Entry Portal Handle (7167-4092) and Entry Portal Tube (7167-4060). The pieces will lock in place securely at either 0° or 180°.

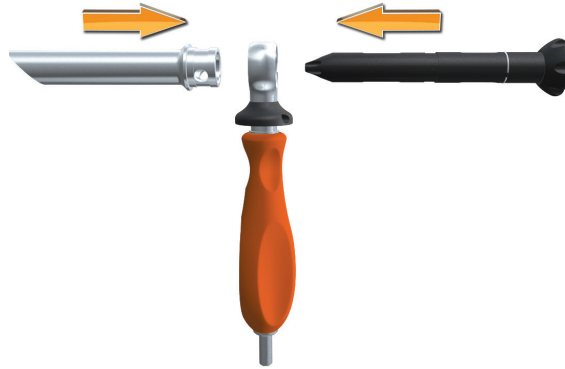

A longitudinal incision is made proximal to the greater trochanter. Carry the incision through to the fascia and palpate the tip of the greater trochanter.

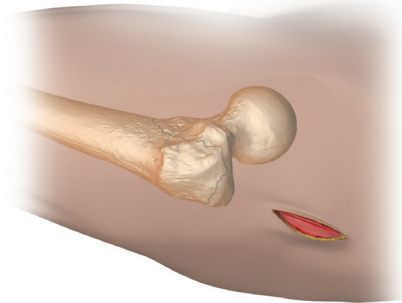

The optimal entry point is located on the medial face of the greater trochanter, 4° from the anatomical axis in the AP and in-line with the intramedullary canal in the lateral.

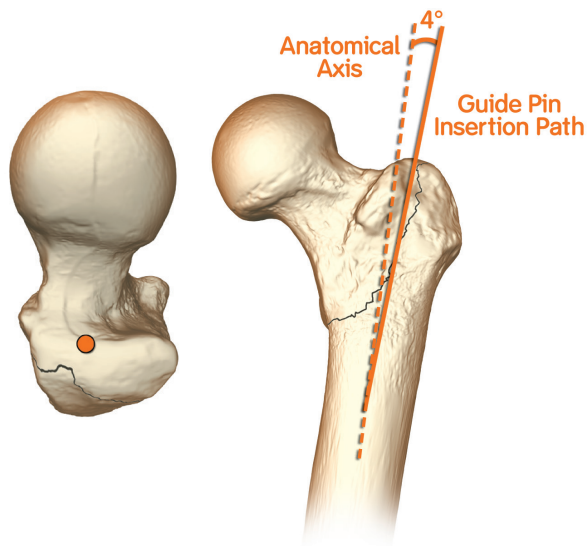

Entry portal acquisition

Insert the Entry Portal Instrumentation through the incision down to bone. Attach a Guide Pin 3.2mm x 343mm (7163-1436) to power via the Mini Connector (7163-1186) and insert 2–3cm into the trochanteric region. Avoid over-insertion of the guide pin as this can establish a false trajectory and lead to fracture malalignment. Confirm guide pin placement in the AP and lateral planes.

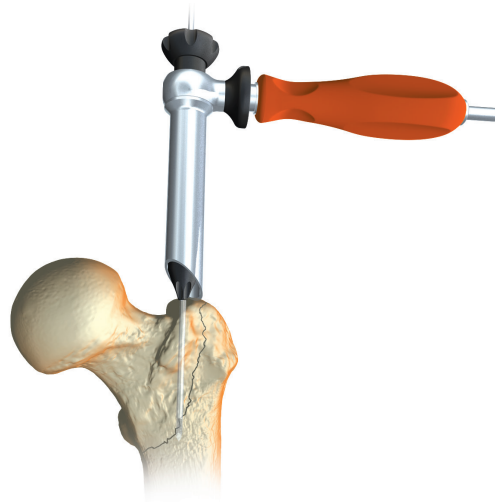

Note In the instance of suboptimal guide pin placement, rotate the Honeycomb within the Entry Portal Tube to the desired location and insert another 3.2mm guide pin.

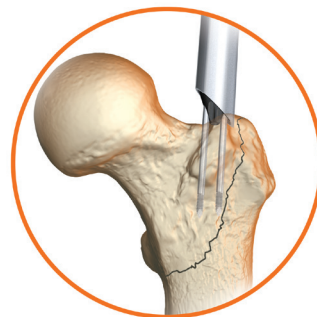

Following guide pin placement, remove the Honeycomb from the Entry Portal Tube along with any additionally inserted guide pins. Insert the 12.5mm Entry Reamer (7163-1116) into the 16mm Channel Reamer (7167-4062)* and attach to power. Advance the assembly through the Entry Portal Instrumentation 1-2cm into the trochanteric region.

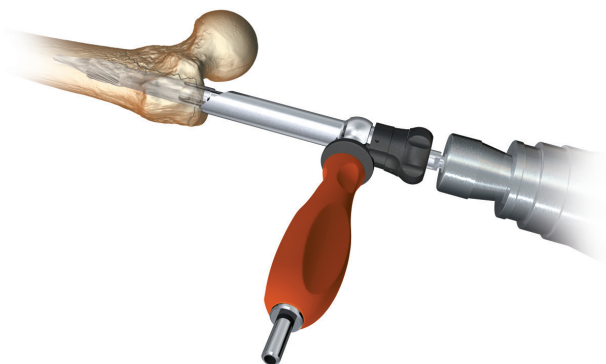

* Also available: 17mm Channel Reamer (7167-4063)

Adjust the angle of the reamer assembly to the desired trajectory and advance to the positive stop on the Entry Portal Tube. The channel reamer will be at the level of the lesser trochanter. If the Entry Portal Instrumentation is not used, the channel reamer must be inserted to the level of the lesser trochanter.

Confirm the reamer assembly's final position and fracture reduction in both the AP and lateral planes. Remove the reamer assembly and guide pin.

Note If inserting a long INTERTAN® nail, leave the channel reamer in place.

Note In the instance of hard bone, it may be necessary to use the 17mm Channel Reamer.

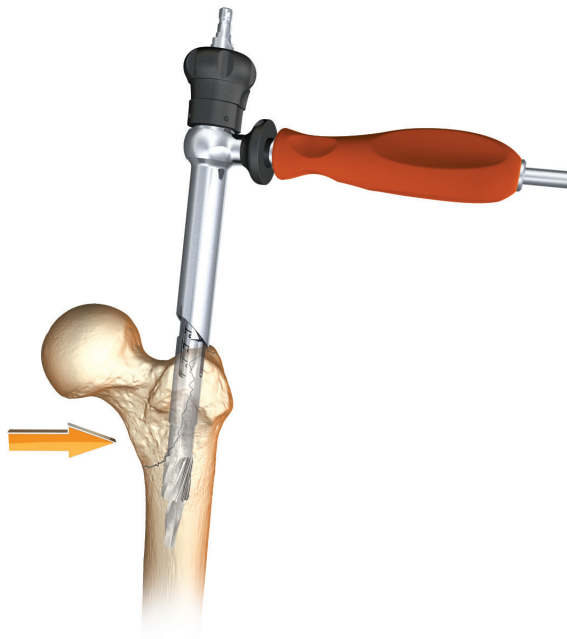

Instruments for fracture reduction and intramedullary reaming (long nail)



Entry Portal Tube
Cat. No. 7167-4060



Entry Portal Handle
Cat. No. 7167-4092



Gripper
Cat. No. 7167-4080



Ruler
Cat. No. 7167-4079



16mm Channel Reamer*
Cat. No. 7167-4062



T-Handle
Cat. No. 7167-4076



Reamer Heads
Cat. No. 7111-8231 to 7111-8256*



Reamer Shaft
Cat. No. 7111-8200



Reducer
Cat. No. 7167-4077

3.0mm x 1000mm Ball Tip Guide Rod
Cat. No. 7163-1626

*Also available: 17mm Channel Reamer (7167-4063)

Intramedullary reaming

Fracture reduction

Insert the back end of the 3.0mm Ball Tip Guide Rod (7163-1626) into the front end of the Gripper (7167-4080) and gently close the trigger-grip. Connect the Reducer and Reducer Connector (7167-4077) so that the words "Slot Orientation" are in line with the opening at the tip. Complete the Reducer assembly by connecting it to the T-Handle (7167-4076).



Introduce the Reducer into the intramedullary canal through the channel reamer and Entry Portal Instrumentation. Care should be taken to maintain fracture reduction. Pass the ball tip guide rod through the back of the T-Handle and insert to the desired depth using the Reducer's curved tip to avoid any areas of comminution. The guide rod should be center-center in the AP and lateral views.

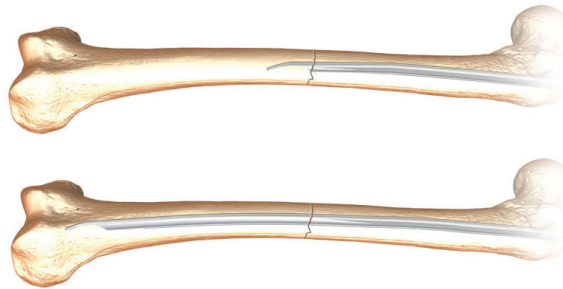

Once the guide rod is in position, detach the Gripper and remove the Reducer from the intramedullary canal. Slide the Obturator (7167-4078) into the back of the T-Handle during extraction in order to maintain guide rod position within the canal.

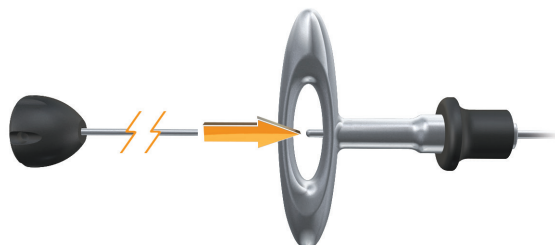

Implant measurement (long nails)

After Reducer removal, re-confirm guide rod position in the distal femur. Advance the Ruler (7167-4079) over the guide rod through the channel reamer and Entry Portal Instrumentation. The metal tip of the Ruler should be at the level of the greater trochanter.

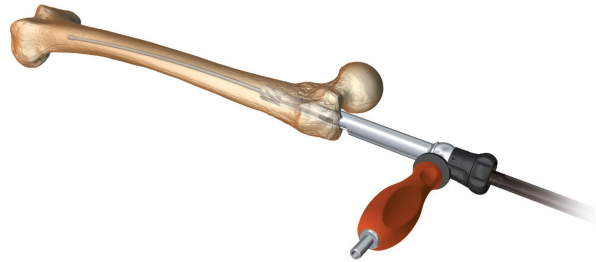

Confirm guide rod position in the window at the proximal end of the Ruler as shown in order to ensure accurate implant measurement. Push down on the top of the Ruler until contact is made with the guide rod. Implant length is read from the exposed calibrations near the thumbwheel on the Ruler.



Note Resistance on the Ruler may be adjusted by tightening or loosening the thumbwheel.

Intramedullary reaming (optional)

Preparing the canal

Beginning with the 9.0mm End Cutting Reamer Head (7111-8231) and Flexible Reamer Shaft (7111-8200), ream the intramedullary canal sequentially in half millimeter increments to a size* 1-1.5mm larger than the selected nail size. Ensure guide rod position during reaming by inserting the Obturator into the back of the Reamer unit during retraction. Continue to confirm guide rod position throughout reaming. Periodically move the Reamer back and forth in the canal to clear debris from the cutting flutes.

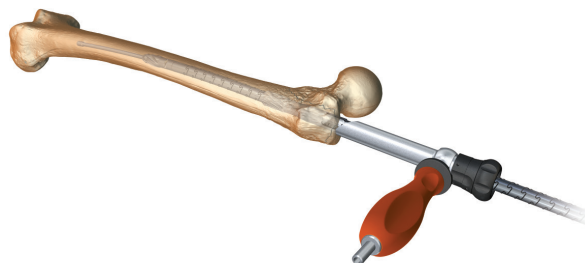

Note The channel reamers will not accommodate Reamer Heads larger than 12.5mm.

*The largest Reamer Head that the TRIGEN® Base Instrument Tray can hold is 16.0mm. Larger sizes are available in the SculptOR Reamer Set (7111-8330)

Instruments for nail assembly and insertion



Drill Guide Handle
Cat. No. 7167-4001

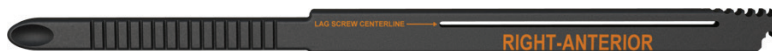

Alignment Arm
Cat. No. 7167-4066



Alignment Tower
Cat. No. 7167-4018



Guide Bolt
Cat. No. 7167-4071



Drill Guide Drop 125° and 130°
Cat. No. 7167-4002 and 7167-4003



T-Handle
Cat. No. 7167-4076



Slotted Hammer
Cat. No. 7167-4082

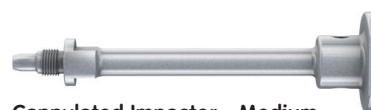

Cannulated Impactor - Medium
Cat. No. 7167-5081



Guide Bolt Wrench
Cat. No. 7163-1140



INTERTAN® Lag Screw Drill
Cat. No. 7167-4540



INTERTAN Gold Lag Screw Drill Sleeve
Cat. No. 7167-4523

Nail insertion

Nail assembly

Attach the Drill Guide Handle (7167-4001) to the nail with the Guide Bolt (7167-4071) and tighten with the Guide Bolt Wrench (7163-1140) and T-Handle. The nail can only be attached to the Drill Guide Handle in one way. Attach the desired Drill Guide Drop (7167-4002, 7167-4003) to the Drill Guide Handle and insert the INTERTAN® Lag Screw Drill Sleeve (7167-4523) into the drop until it locks. Verify targeting accuracy by passing the INTERTAN Lag Screw Drill (7167-4540) through the assembly. An incorrectly attached nail will not target. Attach the Cannulated Impactor (7167-5081) to the Drill Guide Handle and remove the Drill Guide Drop/Lag Screw Drill Sleeve for insertion.

Note To ease assembly of the Nail onto the Drill Guide, there are Nail Mounting Fixtures provided in the Tray that are designed to hold the distal end of the Nail during assembly.

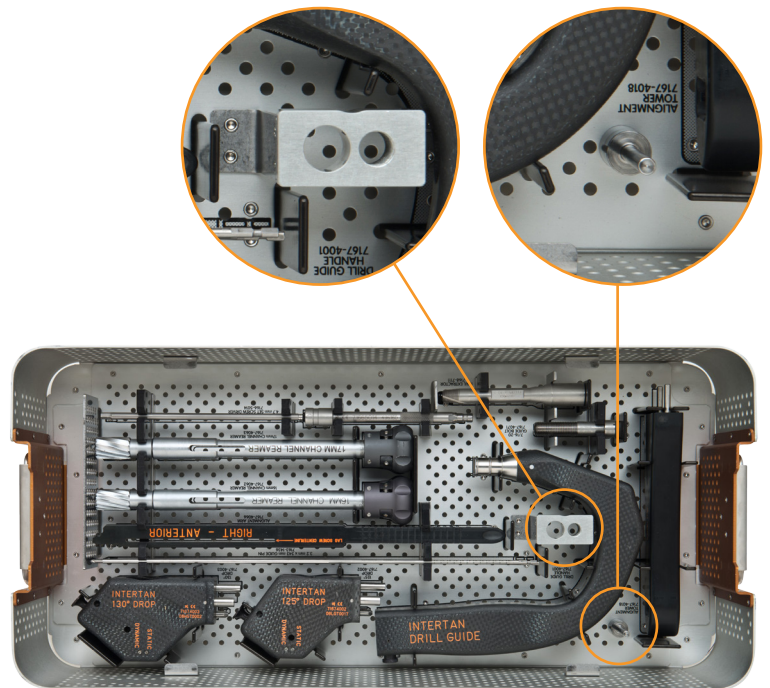

Insertion

Orient the Drill Guide Handle in the lateral position and manually advance the nail into the proximal femur.

Note Do not definitively seat the nail until femoral neck anteversion has been determined. Further insertion of the nail may be required to adequately seat the implant.



For long nails, begin insertion with the Drill Guide Handle in the AP plane. As the nail taper reaches the isthmus of the canal, rotate the handle to the lateral position. Light hammer blows may be necessary when implanting long nails.



Nail anteversion

Nail anteversion Under fluoroscopy, adjust the drill guide until the wire embedded in the handle transects the nail and the femoral neck and head in the lateral view. If desired, gently impact the nail with the Slotted Hammer (7167-4082) to set anteversion.

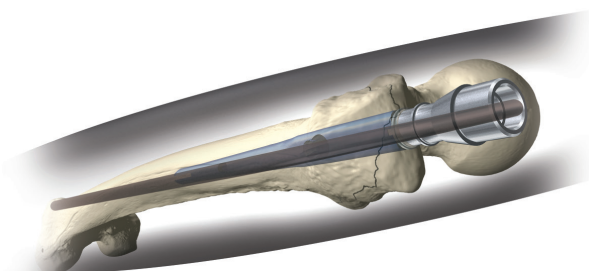

Insertion depth

To confirm nail insertion depth, orient the C-Arm in the AP plane and attach the desired Drill Guide Drop to the Drill Guide Handle. Attach the Alignment Tower (7167-4018) to the drop and slide the back end of the Alignment Arm (7167-4066) into the tower.



The Alignment Arm represents the location of both lag and compression screws prior to insertion. With the C-Arm in the AP, note the position of the Alignment Arm under fluoroscopy. The radiolucent slot in the center of the arm should be center-center in the femoral neck and head. This represents the central axis of both the 11mm Subtrochanteric and 11mm Integrated Interlocking Lag Screw. The compression screw sits beneath the lag screw in the Integrated Screw formation. Definitively seat the nail using the Slotted Hammer. Remove the Impactor from the Drill Guide Handle and the 3.0mm Ball Tip Guide Rod from the intramedullary canal if used.

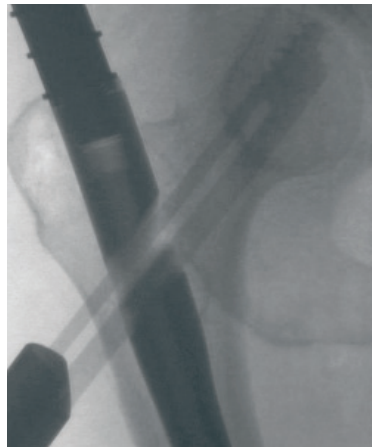

Note After definitively seating the nail, confirm that the nail and Drill Guide Handle are securely connected as hammering can loosen the Guide Bolt.

Proximal locking overview

Integrated Interlocking Screws

1. Insert the Guide Pin 3.2mm x 343mm
2. Measure for the lag screw
3. Drill the lateral cortex with the 7.0mm Compression Screw Starter Drill
4. Drill with the 7.0mm Compression Screw Drill
5. Insert the Anti-Rotation Bar
6. Drill over the guide pin with the Lag Screw Drill
7. Insert the Integrated Interlocking Lag Screw
8. Remove the Anti-Rotation Bar
9. Insert the Integrated Interlocking Compression Screw
10. Engage the Cannulated Set Screw (optional)



Subtrochanteric Lag Screw

1. Insert the Guide Pin 3.2mm x 343mm
2. Measure for the lag screw
3. Drill over the guide pin with the Lag Screw Drill
4. Insert the Subtrochanteric Lag Screw
5. Attach the Compressing Dial to compress the fracture
6. Engage the Cannulated Set Screw (essential)



Instruments for proximal locking



Drill Guide Handle
Cat. No. 7167-4001



Mini Connector
Cat. No. 7163-1186



INTERTAN® 3.2mm Guide Pin Sleeve
Cat. No. 7167-4532



Guide Pin 3.2mm x 343mm
Cat. No. 7163-1436



Drill Guide Drop 125° and 130°
Cat. No. 7167-4002 and 7167-4003

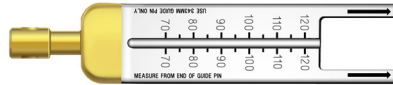

INTERTAN Lag Screw Length Gauge
Cat. No. 7167-4558



INTERTAN Lag Screw Drill Sleeve
Cat. No. 7167-4523

Proximal locking

Lag Screw Drill Sleeve insertion

Make an incision at the site of lag screw entry and insert the INTERTAN® Lag Screw Drill Sleeve (7167-4523) into the Drill Guide Drop until it locks.



Lag Screw Guide Pin insertion

Pass the INTERTAN 3.2mm Guide Pin Sleeve (7167-4532) through the Lag Screw Drill Sleeve down to bone.



Attach a Guide Pin 3.2mm x 343mm to power via the Mini Connector and insert through the Guide Pin Sleeve to the desired position in the femoral neck and head.



Confirm Guide Pin position in both the AP and lateral planes. The Guide Pin should be center-center in both views with a Tip-Apex Distance of less than 25mm¹.

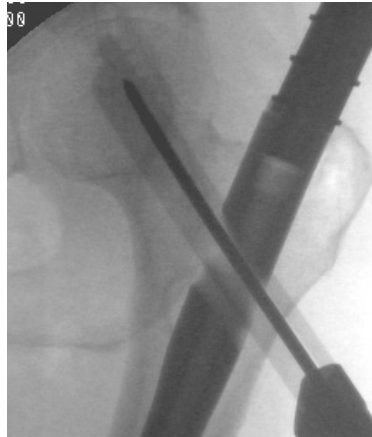
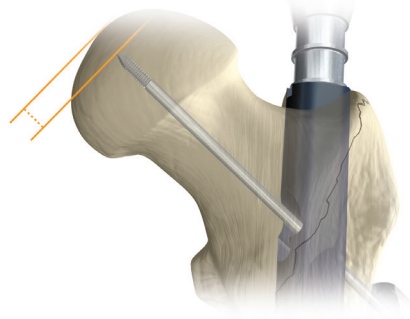

Lag screw measurement

Slide the INTERTAN[®] Lag Screw Length Gauge (7167-4558) over the Guide Pin to the back of the Lag Screw Drill Sleeve. Lag Screw length is taken from the exposed calibrations at the end of the Guide Pin.

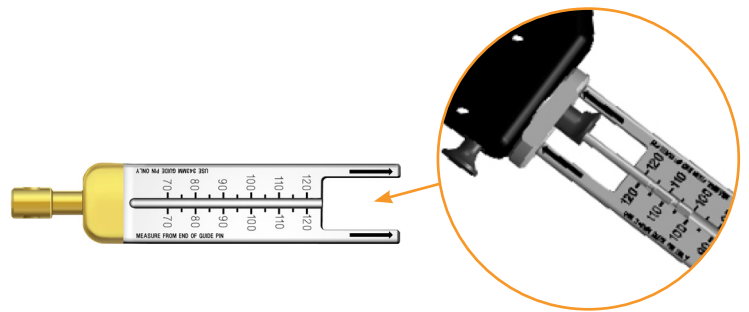

Note The Lag Screw Length Gauge measures to the tip of the Guide Pin.

The TRIGEN[®] INTERTAN nail may be inserted with either **Integrated Interlocking Screws** (pp. 23–27) or a **single Subtrochanteric Lag Screw** (pp. 29–31). Select the desired construct and proceed with lag screw insertion.

¹ The Value of the Tip-Apex distance in predicting failure of fixation of peritrochanteric fractures of the hip. MR Baumgaertner, SL Curtin, DM Lindskog and JM Keggi. The Journal of Bone and Joint Surgery of America, 77: pp.1058-1064, 1995.

Instruments for Integrated Interlocking Screw insertion



Drill Guide Handle
Cat. No. 7167-4001



T-Handle
Cat. No. 7167-4076



INTERTAN® Lag Screw Drill Sleeve
Cat. No. 7167-4523



Drill Guide Drop 125° and 130°
Cat. No. 7167-4002 and 7167-4003



Guide Pin 3.2mm x 343mm
Cat. No. 7163-1436



INTERTAN 7.0mm Compression Screw Starter Drill
Cat. No. 7167-4570



Lag Screw Tap
Cat. No. 7167-4009



7.0mm Compression Screw Drill
Cat. No. 7167-4034



INTERTAN Lag Screw Drill
Cat. No. 7167-4540



Compression Screw Hexdriver
Cat. No. 7167-4035



Anti-Rotation Bar
Cat. No. 7167-4041



Set Screwdriver
Cat. No. 7166-5014



Lag Screwdriver
Cat. No. 7167-4067

Integrated Interlocking Screw insertion

Confirm Guide Pin position. Attach the INTERTAN® 7.0mm Compression Screw Starter Drill (7167-4570) to power and insert into the Lag Screw Drill Sleeve beneath the Guide Pin. Advance the Compression Screw Starter Drill under power until it abuts with the back end of the Lag Screw Drill Sleeve.

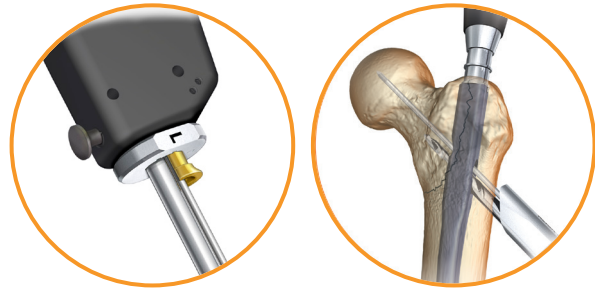
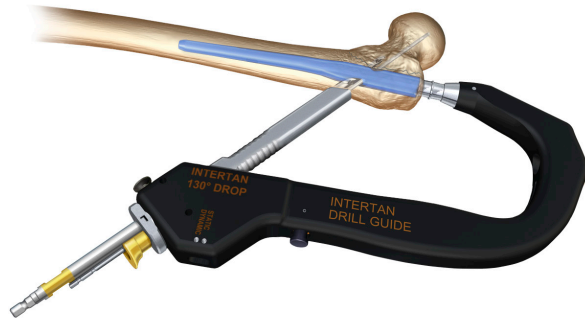

Attach the 7.0mm Compression Screw Drill (7167-4034) to power and insert through the Lag Screw Drill Sleeve into the hole created by the Compression Screw Starter Drill. Advance the Compression Screw Drill under fluoroscopy to a depth 5mm less than the measurement taken from the Guide Pin. The mark on the Compression Screw Drill will be flush with the back of the Lag Screw Drill Sleeve.

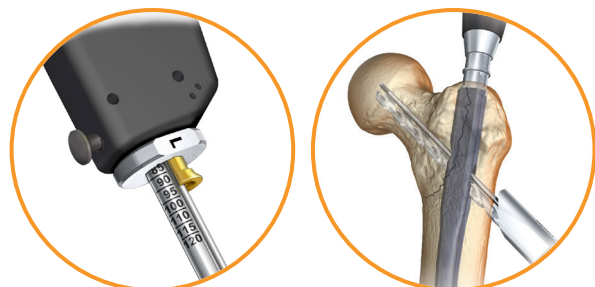
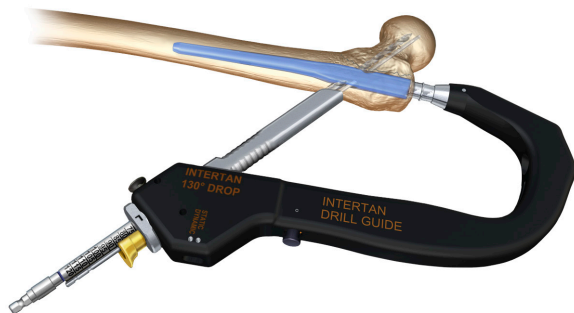

Remove the Compression Screw Drill and manually insert the Anti-Rotation Bar (7167-4041) into the same hole. If the Anti-Rotation Bar meets with resistance upon insertion, remove it and re-drill with the Compression Screw Drill.



Confirm Guide Pin position and remove the 3.2mm Guide Pin Sleeve. Attach the INTERTAN® Lag Screw Drill (7167-4540) to power and insert into the Lag Screw Drill Sleeve over the Guide Pin. Drill to the depth measured for the Lag Screw. The calibrations on the Lag Screw Drill will be flush with the back of the Lag Screw Drill Sleeve. Re-confirm Lag Screw Drill position under fluoroscopy.

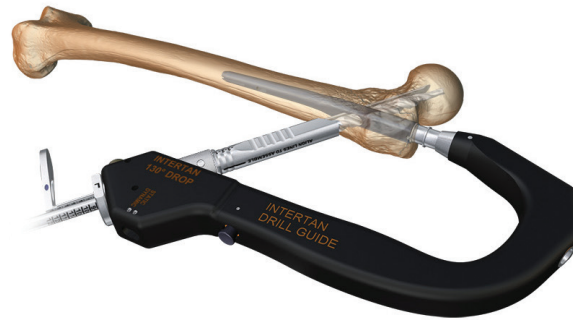

Note In the instance of hard bone, it may be necessary to use the Lag Screw Tap (7167-4009) prior to lag screw insertion.

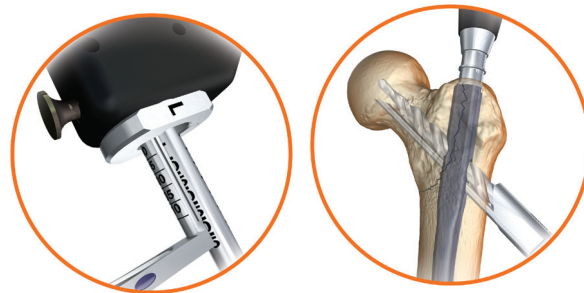

Integrated Interlocking Screw insertion: No compression

Select a Lag Screw equal in length to the drilled depth.

Example Drilling depth 100mm
 Screw length 100mm

Align the back end of the appropriate length Interlocking Lag Screw with the Lag Screwdriver (7167-4067). Thread the Retaining Rod into the Lag Screw and tighten. Insert the assembly into the Lag Screw Drill Sleeve over the Guide Pin.

Advance the Lag Screw manually until the "0mm" mark on the Lag Screwdriver is flush with the back of the Lag Screw Drill Sleeve and the T-Handle is perpendicular to the Drill Guide Assembly. The groove on the undersurface of the Lag Screwdriver must be oriented towards the patient's feet in order to remove the Anti-Rotation Bar.

Remove the Anti-Rotation Bar and attach the Compression Screw that was packaged with the Lag Screw to the Compression Screw Hexdriver (7167-4035). Attach the T-Handle to the Compression Screw Hexdriver and insert the assembly into the Lag Screw Drill Sleeve beneath the Lag Screwdriver. Advance the Compression Screw until the blue line on the Compression Screw Hexdriver is flush with the back of the Lag Screw Drill Sleeve.

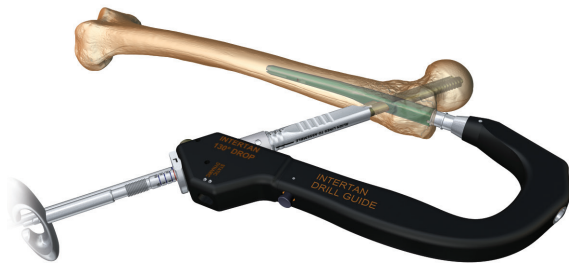
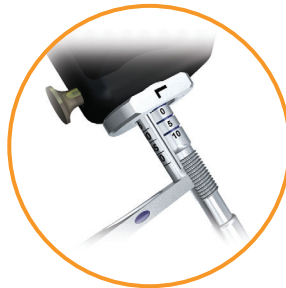
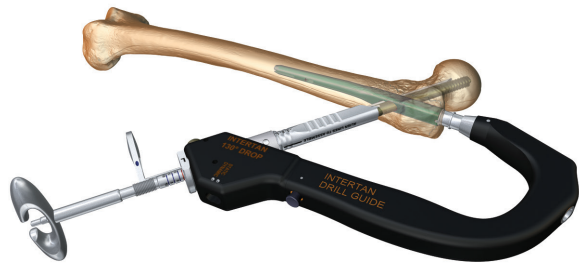

Integrated Interlocking Screw insertion: With compression

Select a Lag Screw equal in length to the drilled depth minus the desired amount of compression.

Example	Drilling depth	100mm
	Compression	10mm
	Screw length	90mm

Align the back end of the appropriate length Integrated Interlocking Lag Screw with the Lag Screwdriver (7167-4067). Thread the Retaining Rod into the Lag Screw and tighten. Insert the assembly into the Lag Screw Drill Sleeve over the Guide Pin.

Advance the Lag Screw manually until the mark on the Lag Screwdriver representing the desired amount of compression is flush with the back of the Lag Screw Drill Sleeve and the T-Handle is perpendicular to the Drill Guide assembly. The groove on the under-surface of the Lag Screwdriver must be oriented towards the patient's feet in order to remove the Anti-Rotation Bar.



Remove the Anti-Rotation Bar and attach the Compression Screw that was packaged with the Lag Screw to the Compression Screw Hexdriver (7167-4035). Attach the T-Handle to the Compression Screw Hexdriver and insert the assembly into the Lag Screw Drill Sleeve beneath the Lag Screwdriver. Advance the compression screw until the blue line on the Compression Screw Hexdriver is flush with the back of the Lag Screw Drill Sleeve.



After releasing traction on the affected limb, compression is achieved by advancing the Compression Screw assembly clockwise until the “0mm” mark on the Lag Screwdriver is visible. As the head of the Compression Screw abuts within the nail, the gear mechanism of the Integrated Interlocking Screws will compress the fracture. It is recommended to stop compression when the “0mm” mark appears. However, extra compression (2-3mm) may be achieved by advancing the Compression Screw Hexdriver until the red mark on the Lag Screwdriver appears.

Note It is not recommended to exceed 10mm of compression.

Integrated Interlocking Screw insertion: Locking the Cannulated Set Screw (optional)

Attach the Set Screwdriver to the T-Handle and insert through the top of the Drill Guide Handle and Guide Bolt until it engages with the hex of the Cannulated Set Screw. Turn clockwise to engage the set screw with the Integrated Interlocking Lag Screw.

The Integrated Interlocking Screws are incapable of excessive medial migration and/or rotation within the nail, but can still slide to allow postoperative compression. To facilitate sliding, do not lock the Cannulated Set Screw. Full engagement of the Set Screw with the Lag Screw converts the construct into a fixed angle device.



Instruments for Subtrochanteric Lag Screw insertion



Drill Guide Handle
Cat. No. 7167-4001



Drill Guide Drop 125° and 130°
Cat. No. 7167-4002 and 7167-4003



Set Screwdriver
Cat. No. 7166-5014



T-Handle
Cat. No. 7167-4076



Compressing Dial
Cat. No. 7167-4069



INTERTAN° Lag Screw Drill Sleeve
Cat. No. 7167-4523

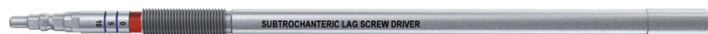

Subtrochanteric Lag Screwdriver
Cat. No. 7167-4068



3.2mm x 343mm Guide Pin
Cat. No. 7163-1436



Lag Screw Drill
Cat. No. 7167-4540



Lag Screw Tap
Cat. No. 7167-4009

Subtrochanteric Lag Screw insertion

Confirm Guide Pin position and remove the 3.2mm Guide Pin Sleeve. Attach the INTERTAN® Lag Screw Drill (7167-4540) to power and insert into the Lag Screw Drill Sleeve over the Guide Pin. Drill to the depth measured for the Lag Screw. The calibrations on the Lag Screw Drill will be flush with the back of the Lag Screw Drill Sleeve. Re-confirm Lag Screw Drill position under fluoroscopy.

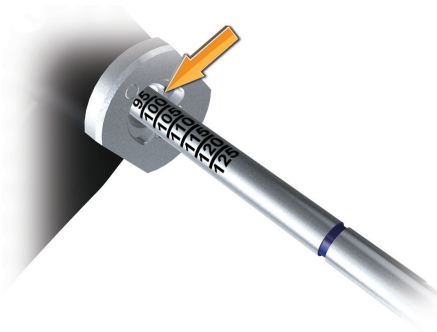

Subtrochanteric Lag Screw insertion: No compression

Select a lag screw equal in length to the drilled depth.

Example

Drilling depth	100mm
Screw length	100mm

Align the back end of the appropriate length Subtrochanteric Lag Screw with the Subtrochanteric Lag Screwdriver (7167-4068). Thread the Retaining Rod into the Lag Screw and tighten the assembly. Attach the Compressing Dial (7167-4069) to the Lag Screwdriver and turn clockwise until the "0mm" mark on the Lag Screwdriver is flush with the base of the dial.

Attach the T-Handle to the Lag Screwdriver and insert the assembly into the Lag Screw Drill Sleeve over the Guide Pin. Advance the Lag Screwdriver manually until the Compressing Dial is flush with the back of the Lag Screw Drill Sleeve. For proper Lag Screw alignment with the pre-assembled Cannulated Set Screw, the T-Handle must be either parallel or perpendicular to the Drill Guide assembly.



Subtrochanteric Lag Screw insertion: With compression

Select a Lag Screw equal in length to the drilled depth minus the desired amount of compression.

Example	Drilling depth	100mm
	Compression	10mm
	Screw length	90mm

Align the back end of the appropriate length Subtrochanteric Lag Screw with the Subtrochanteric Lag Screwdriver (7167-4068). Thread the Retaining Rod into the Lag Screw and tighten the assembly. Attach the Compressing Dial (7167-4069) to the Lag Screwdriver and turn clockwise until the mark on the Lag Screwdriver representing the desired amount of compression is flush with the base of the dial.

Attach the T-Handle to the Lag Screwdriver and insert the assembly into the Lag Screw Drill Sleeve over the Guide Pin. Advance the Lag Screwdriver manually until the Compressing Dial is flush with the back of the Lag Screw Drill Sleeve. For proper Lag Screw alignment with the pre-assembled Cannulated Set Screw, the T-Handle must be either parallel or perpendicular to the Drill Guide assembly. Release any traction on the affected limb to allow for fracture compression.

Compression is achieved by turning the Compressing Dial clockwise until the "0mm" mark on the Lag Screwdriver is visible at the base of the dial. It is recommended to stop compression when the "0mm" mark appears. However, extra compression (2-3mm) may be achieved by turning the Compressing Dial until the red mark on the Lag Screwdriver appears.

Note It is not recommended to exceed 10mm of compression.



Subtrochanteric Lag Screw insertion: Locking the Cannulated Set Screw

Attach the Set Screwdriver (7116-5014) to the T-Handle and insert through the top of the Drill Guide Handle and Guide Bolt until it engages with the hex of the Cannulated Set Screw. Turn clockwise to engage the Set Screw with the Subtrochanteric Lag Screw. To prevent Lag Screw sliding within the nail, firmly engage the Set Screw with the Lag Screw. To allow postoperative sliding, back the Set Screw off 1/4 turn from the Lag Screw once engaged.



Note As all four grooves on the body of the Lag Screw are equal in length, the same amount of sliding may be achieved with the T-Handle in either the perpendicular or parallel position.

To confirm Set screw position, reattach the T-Handle to the Subtrochanteric Lag Screwdriver and turn it within the Lag Screw Drill Sleeve. If the Lag Screwdriver will not turn, the Set Screw was successfully engaged. If it turns, repeat the previous steps for locking the Set Screw.

Instruments for distal locking



T-Handle

Cat. No. 7167-4076



4.0mm Short Drill**

Cat. No. 7163-1117



Screwdriver Release

Cat. No. 7167-4084



Screw Length Sleeve

Cat. No. 7167-4085



Screw Depth Gauge

Cat. No. 7163-1189



4.0mm Long Pilot Drill*

Cat. No. 7163-1110



4.0mm Drill Sleeve

Cat. No. 7167-4083



9.0mm Drill Sleeve

Cat. No. 7163-1152



Medium Hexdriver

Cat. No. 7163-1066



Short Hexdriver

Cat. No. 7163-1068



Mini Connector

Cat. No. 7163-1186

Distal locking

Short nail: 18cm and 20cm

Reconfirm fracture reduction via radiographic imaging. Make a small incision at the site of screw entry and insert the 9.0mm Drill Sleeve (7163-1152) and 4.0mm Drill Sleeve (7167-4083) through the desired slot on the Drill Guide. Drop down to bone. Drill both cortices with the 4.0mm Long Pilot Drill*.

Measure for screw length using either the calibrations on the 4.0mm Long Pilot Drill* or by removing the 4.0mm Drill Sleeve and using the Screw Depth Gauge (7163-1189). Attach the appropriate length 5.0mm locking screw to the Medium Hexdriver (7163-1066) and insert through the 9.0mm Drill Sleeve on power until the laser etched ring on the hexdriver reaches the back of the drill sleeve. Attach the T-Handle to the hexdriver and tighten the locking screw by hand.

Note If encountering hard bone, the TRIGEN® 4.7 Diaphyseal Drill (7170-0006) can be used through the gold sleeve. This item is not included in the sets.

Long nail: 26-46cm

Distal locking is performed in the lateral plane using a free-hand technique. Reconfirm fracture reduction and align the C-Arm over the desired locking hole. Obtain a “perfect circle” image of the locking hole and use a blunt object to approximate the location of the locking hole by dimpling the skin.

Make a stab incision at the site of screw entry, insert the 4.0mm Short Drill (7163-1117)** down to bone, and drill both cortices.

Measure for screw length using the Screw Depth Gauge. Alternatively, leave the 4.0mm Short Drill in place, insert the Screw Length Sleeve (7167-4085) down to bone, and read the exposed calibrations off the drill. Insert the appropriate length 5.0mm locking screw using either the Medium or Short Hexdriver (7163-1068) and T-Handle

Note If encountering hard bone, the TRIGEN 4.7/ 4.0 Diaphyseal Drill (7164-1123) can be used***.

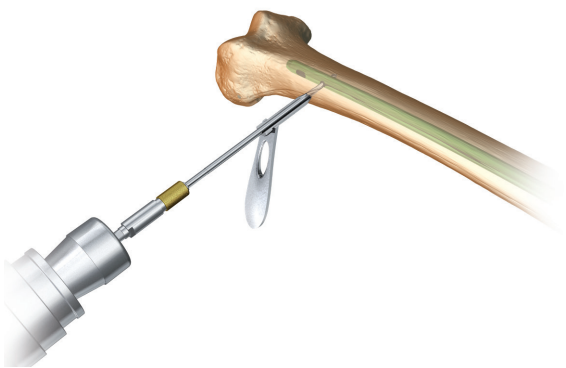
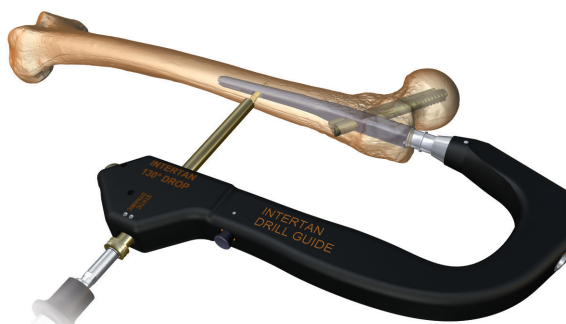
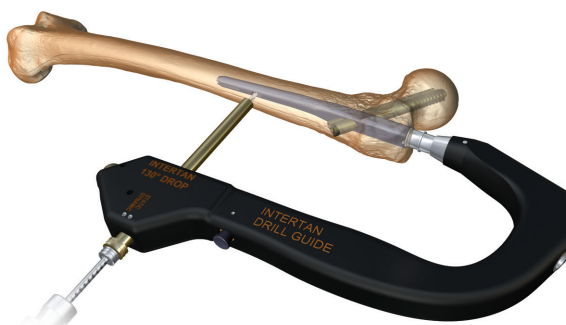

* 4.0mm AO Long Drill (7163-1121) is interchangeable with 4.0mm Long Pilot Drill (7163-1110)

** 4.0mm AO Short Drill (7163-1123) is interchangeable with 4.0mm Short Drill (7163-1117)

*** TRIGEN 4.7/4.0mm Diaphyseal Drill is used for free-hand distal locking and will not fit through the 4.0mm Drill Sleeve (7167-4083).

Nail Cap insertion: Optional

Remove the Drill Guide Handle using the Guide Bolt Wrench and T-Handle. Attach the INTERTAN® Nail Cap to the Medium Hexdriver/ T-Handle assembly and insert into the top of the nail until tight.

Note If cross-threading occurs, rotate the nail cap counterclockwise until its threads line up with those of the nail. Proceed with insertion until tight.

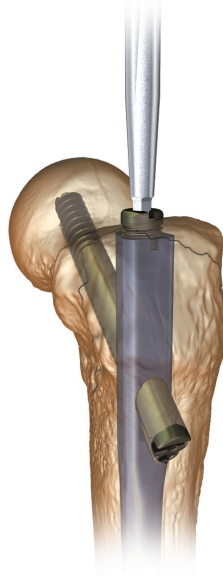

Closure

Obtain Final AP and lateral radiographic images to confirm implant position and fracture reduction. Wound closure follows standard technique.



Instruments for implant removal



Guide Pin 3.2mm X 343mm
Cat. No. 7163-1436



Mini Connector
Cat. No. 7163-1186



12.5mm Entry Reamer
Cat. No. 7163-1116



Disposable Nail Extractor
Cat. No. 7163-1320



Impactor
Cat. No. 7167-4081



Cannulated Impactor – Long*
Cat. No. 7163-1185

3.0mm X 1000mm Ball Tip Guide Rod**
Cat. No. 7163-1626



Compression Screw Hexdriver
Cat. No. 7167-4009



Slotted Hammer
Cat. No. 7167-4082



Set Screwdriver
Cat. No. 7166-5014



T-Handle
Cat. No. 7167-4076



Medium Hexdriver
Cat. No. 7163-1066



Lag Screwdriver
Cat. No. 7167-4067

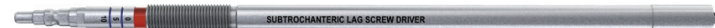

Subtrochanteric Lag Screwdriver
Cat. No. 7167-4068

*The Cannulated Impactor, Long is found in the original TRIGEN® Instrument Set (7163-1326)

**Additional Guide Rods listed on page 38

Implant removal: Optional

Disengage the Cannulated Set Screw

Remove the nail cap if implanted using the Medium Hexdriver and T-Handle. Attach the Set Screwdriver to the T-Handle and insert into the top of the nail until it engages with the hex of the Cannulated Set Screw. Turn counterclockwise to fully disengage the set screw from the lag screw.



Subtrochanteric Lag Screw removal

Attach a Guide Pin 3.2mm x 343mm to power via the Mini Connector and insert into the back of the Subtrochanteric Lag Screw under fluoroscopy. This may also be performed manually. Slide the Subtrochanteric Lag Screwdriver over the guide pin and engage it with the back of the lag screw. Thread the retaining rod into the lag screw and attach the T-Handle to the back of the lag screwdriver. Remove using counterclockwise turns of the assembly.

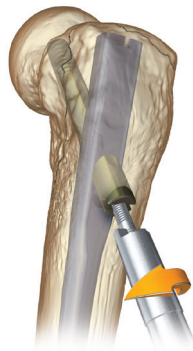

Integrated Interlocking Screw removal

Insert the Compression Screw Hexdriver into the back of the Compression Screw and engage the retaining rod. Attach the T-Handle to the back of the hexdriver and remove using counterclockwise turns of the assembly.

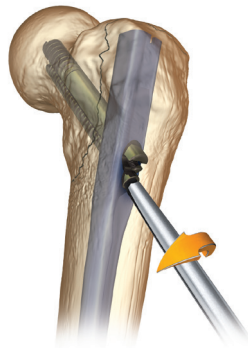

Under fluoroscopy, insert a Guide Pin 3.2mm x 343mm into the back of the Integrated Interlocking Lag Screw. Slide the Lag Screwdriver over the guide pin and engage it with the back of the lag screw. Thread the retaining rod into the lag screw and remove using counterclockwise turns of the assembly.

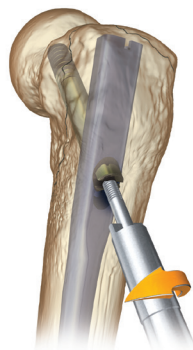

Open nail extraction technique

Remove all but one of the locking screws using the Medium Hexdriver and T-Handle. Thread the Nail Extractor (7168-7111) into the Impactor or One Piece Impactor (7163-1185)* and introduce the extraction assembly into the top of the nail. Remove the final locking screw(s) and extract the nail with a back-slapping motion using the Slotted Hammer.

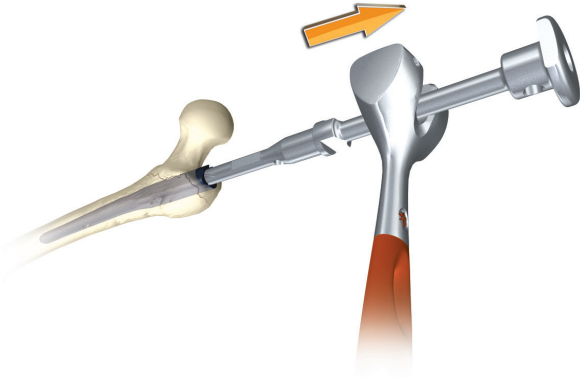

Percutaneous nail extraction technique

This technique assumes the absence of a nail cap. Attach a Guide Pin 3.2mm x 343mm to power via the Mini Connector and insert into the top of the nail under fluoroscopy. This may also be performed manually.

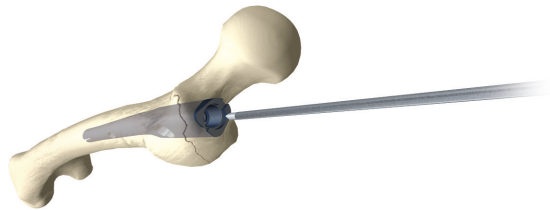

Attach the 12.5mm Entry Reamer to power. Make a one inch incision around the guide pin and advance the entry reamer over the guide pin and into the top of the nail to remove bony ingrowth. Nail extraction follows the previously described technique.

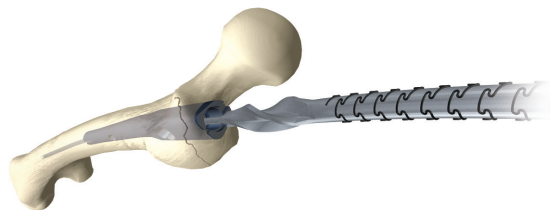

Note The tip of the entry reamer is straight for approximately one inch before flaring out. It is this portion of the entry reamer that enters the top of the nail.

* The One Piece Impactor is found in the original TRIGEN® Instrument Set (7163-1326)

Implant removal: Optional

Guide Rod Jamming Technique

Advance the end of a 3.0mm Ball Tip Guide Rod through the end of the nail. Insert a smooth 2.0mm Guide Rod (7111-8280) in the same manner. With both guide rods in place, attach the Gripper to the end of the 3.0mm Ball Tip Guide Rod and pull it back so that it wedges the ball tip against the smooth 2.0mm Guide Rod. Backslap against the Gripper with the Slotted Hammer to extract the nail.

Guide Rods

<i>Cat. No.</i>	<i>Description</i>
-----------------	--------------------

7111-8280	2.0mm x 900mm Smooth (RUSSELL-TAYLOR)*
-----------	--

7111-8202	3.0mm x 900mm Ball Tip (RUSSELL-TAYLOR)*
-----------	--

7163-1626	3.0mm x 1000mm Ball Tip (TRIGEN®)
-----------	-----------------------------------

Additional Removal Items

<i>Cat. No.</i>	<i>Description</i>
-----------------	--------------------

115074	Large Extractor Hook**
--------	------------------------

115073	Small Extractor Hook**
--------	------------------------

914658	Large Easy Out**
--------	------------------

914659	Small Easy Out**
--------	------------------

* Available sterile. For nail removal only, do not use for nail insertion

** Located in RUSSELL-TAYLOR Extraction Kit (Set #7508) available through Loaners

Catalog Information

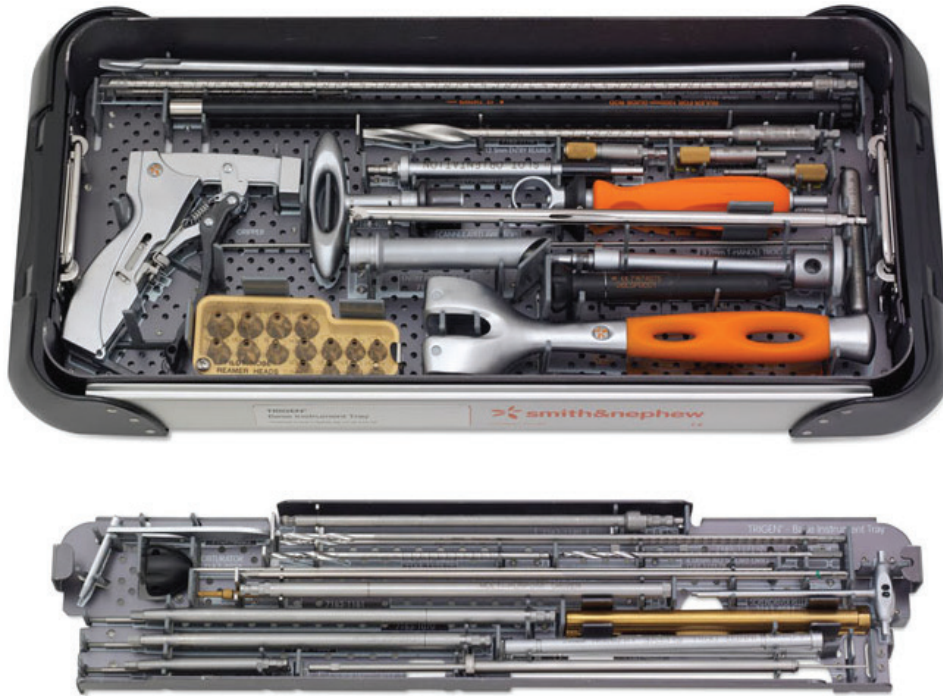

TRIGEN° INTERTAN° Base Instrument Set*

Set No. 7167-4012

Instrument Case

Cat. No.	Description	Qty
7112-9401	Small Outer Case	1 ea
7112-9402	Lid for Outer Case	1 ea
7167-4021	TRIGEN Base Tray	1 ea

Instruments

Cat. No.	Description	Tray Qty	Cat. No.	Description	Tray Qty
7163-1066	Medium Hexdriver	1 ea	7167-4076	T-Handle	1 ea
7163-1068	Short Hexdriver	1 ea	7167-4077	Reducer	1 ea
7163-1116	12.5mm Entry Reamer	1 ea	7167-4078	Obturator	1 ea
7163-1140	Guide Bolt Wrench	1 ea	7167-4079	Ruler	1 ea
7163-1152	9.0mm Drill Sleeve	2 ea	7167-4080	Gripper	1 ea
7163-1161	Multipurpose Driver	1 ea	7167-5081	Cannulated Impactor – Medium	1 ea
7163-1186	Mini Connector	1 ea	7167-4082	Slotted Hammer	1 ea
7163-1189	Screw Depth Gauge	1 ea	7167-4083	4.0mm Drill Sleeve	3 ea
7167-4000	Cannulated Awl	1 ea	7167-4084	Screwdriver Release Handle	1 ea
7167-4060	Entry Portal Tube	1 ea	7167-4085	Screw Length Sleeve	1 ea
7167-4074	3.2mm T-Handle Trocar	1 ea	7167-4092	Entry Portal Handle	1 ea
7167-4075	Honeycomb	1 ea			

* Instrument Set pictured with additional instruments

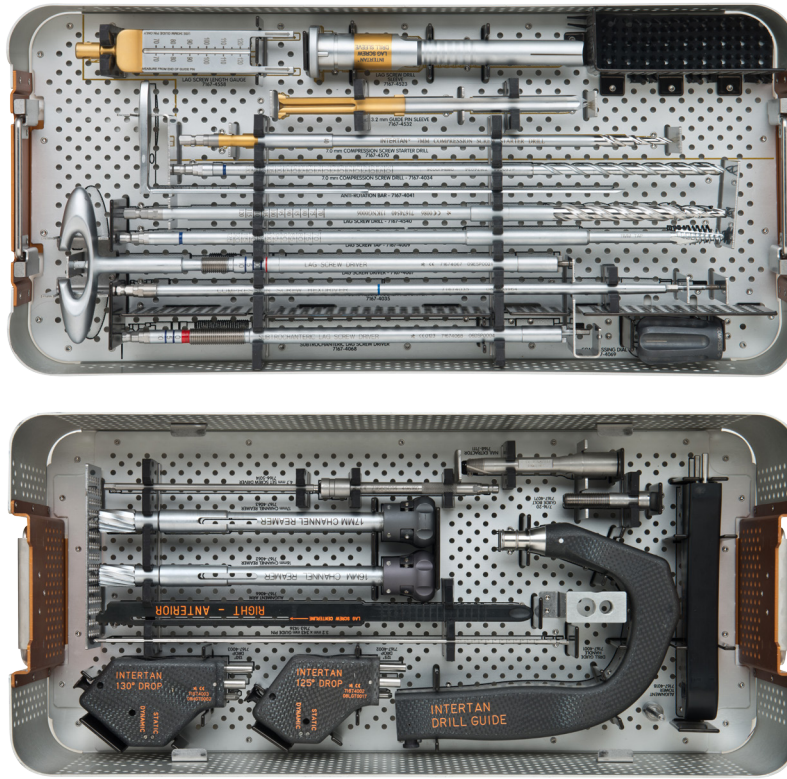

TRIGEN® INTERTAN® Instrument Set-Gold

Set No. 7167-4026

Instrument Case

Cat. No.	Description	Qty
7167-4520	TRIGEN INTERTAN Gold Instrument Tray	1 ea
7167-4521	TRIGEN INTERTAN Gold Top Tray	1 ea
7167-4522	TRIGEN INTERTAN Gold Instrument Tray Lid	1 ea

Instruments

Cat. No.	Description	Tray Qty	Cat. No.	Description	Tray Qty
7166-5014	Set Screw Driver	1 ea	7167-4523	INTERTAN Lag Screw Drill Sleeve	1 ea
7167-4068	Subtrochanteric Lag Screw Driver	1 ea	7167-4041	Anti-Rotation Bar	1 ea
7167-4001	Drill Guide Handle	1 ea	7168-7111	IMHS® CP Nail Extractor	1 ea
7167-4003	130° Drill Guide Drop	1 ea	7167-4532	INTERTAN 3.2mm Guide Pin Sleeve	1 ea
7167-4069	Compressing Dial	1 ea	7167-4034	7.0mm Compression Screw Drill	1 ea
7167-4570	INTERTAN 7.0mm Compression Starter Drill	1 ea	7167-4035	Compression Screw Hexdriver	1 ea
7167-4540	INTERTAN Lag Screw Drill	1 ea	7167-4558	INTERTAN Lag Screw Length Gauge	1 ea
7167-4009	Lag Screw Tap	1 ea	7167-4062	16mm Channel Reamer	1 ea
7167-4071	Guide Bolt	2 ea	7167-4063	17mm Channel Reamer	1 ea
7167-4018	Alignment Tower	1 ea	7167-4066	Alignment Arm	1 ea
7167-4002	125° Drill Guide Drop	1 ea	7167-4067	Lag Screw Driver	1 ea

Disposables

Set No. 7167-1200

Cat. No.	Description	Tray Qty
7163-1121	4.0mm Long AO Pilot Drill, 333mm	2 ea
7163-1123	4.0mm Short AO Pilot Drill, 161mm	2 ea
7163-1626	3.0mm X 1000mm Ball Tip Guide Rod	2 ea
7163-1436	Guide Pin 3.2mm X 343mm	3 ea
7164-1123*	TRIGEN 4.7/4.0 Diaphyseal Drill	

Optional Instruments

Cat. No.	Description	Qty
7163-1070	Long Hexdriver	1 ea
7167-4002	125° Drill Guide Drop	1 ea
7175-1153	AO Mini Connector	1 ea
7163-1187	Trinkle to Mini Connector	1 ea

Implants

INTERTAN® Integrated Interlocking Screw Kits (11.0mm x 7.0mm)

Cat. No.	Description	Qty
7167-7070	70mm Lag Screw/65mm Compression Screw	1
7167-7075	75mm Lag Screw/70mm Compression Screw	1
7167-7080	80mm Lag Screw/75mm Compression Screw	1
7167-7085	85mm Lag Screw/80mm Compression Screw	1
7167-7090	90mm Lag Screw/85mm Compression Screw	1
7167-7095	95mm Lag Screw/90mm Compression Screw	1
7167-7100	100mm Lag Screw/95mm Compression Screw	1
7167-7105	105mm Lag Screw/100mm Compression Screw	1
7167-7110	110mm Lag Screw/105mm Compression Screw	1
7167-7115	115mm Lag Screw/110mm Compression Screw	1
7167-7120	120mm Lag Screw/115mm Compression Screw	1
7167-7125	125mm Lag Screw/120mm Compression Screw	1

5.0mm Internal Hex Captured Locking Screws***

Cat. No.	Length
7164-5025	25mm
7164-5027	27.5mm
7164-5030	30mm
7164-5032	32.5mm
7164-5035	35mm
7164-5037	37.5mm
7164-5040	40mm
7164-5042	42.5mm
7164-5045	45mm
7164-5047	47.5mm
7164-5050	50mm

TRIGEN® Reamer Set: Optional

Set No. 7167-1212

Cat. No.	Description	Qty
7111-8200	SCULPTOR® Flexible Reamer	1 ea
7163-1130	Flexible Reamer Extender	1 ea
7111-8232	9.0mm Reamer Head	1 ea
7111-8233	9.5mm Reamer Head	1 ea
7111-8234	10.0mm Reamer Head	1 ea
7111-8235	10.5mm Reamer Head	1 ea
7111-8236	11.0mm Reamer Head	1 ea
7111-8237	11.5mm Reamer Head	1 ea
7111-8238	12.0mm Reamer Head	1 ea
7111-8239	12.5mm Reamer Head	1 ea
7111-8240	13.0mm Reamer Head	1 ea
7111-8241	13.5mm Reamer Head	1 ea
7111-8242	14.0mm Reamer Head	1 ea
7111-8243**	14.5mm Reamer Head	1 ea
7111-8244**	15.0mm Reamer Head	1 ea
7111-8245**	15.5mm Reamer Head	1 ea
7111-8246**	16.0mm Reamer Head	1 ea

11.0mm Subtrochanteric Lag Screws

Cat. No.	Length
7167-8070	70mm
7167-8075	75mm
7167-8080	80mm
7167-8085	85mm
7167-8090	90mm
7167-8095	95mm
7167-8010	100mm
7167-8005	105mm
7167-8011	110mm
7167-8015	115mm
7167-8012	120mm
7167-8025	125mm

Other Implants

Cat. No.	Description
7167-2030	INTERTAN Compression Screw, 30mm
7167-5030	INTERTAN Set Screw
7167-5040	INTERTAN Nail Cap, 0mm

Replacement Items

Cat. No.	Description
7167-4086	Subtrochanteric Lag Screw Hexdriver Rod
7167-4087	Lag Wrench Retaining Rod Assembly
7167-4088	Compression Screw Hexdriver Shaft

* Items additionally available – not part of Set No. 7167-1200

** Items additionally available – not part of Set No. 7167-1212

*** Additional length 5.0mm Locking Screws available (55-110mm in 2.5mm increments)

TRIGEN[®] INTERTAN[®] Intertrochanteric Antegrade Nails

Short Nails (Blue)

Cat. No.	Distal Diameter	Length	Neck Angle
7167-5383	10mm (10s Nail)	18cm	125°
7167-5384	10mm (10s Nail)	18cm	130°
7167-5385	10mm (10s Nail)	20cm	125°
7167-5386	10mm (10s Nail)	20cm	130°
<hr/>			
7167-5202	11.5mm	18cm	125°
7167-5208	11.5mm	18cm	130°
7167-5205	11.5mm	20cm	125°
7167-5211	11.5mm	20cm	130°
<hr/>			
7167-5203	13mm	18cm	125°
7167-5209	13mm	18cm	130°
7167-5206	13mm	20cm	125°
7167-5212	13mm	20cm	130°



10mm (10s Nail) Diameter Nails
(26cm-46cm) (Lime/Rose)



Left	Right	Length	Neck Angle
7167-5501	7167-5523	26	125°
7167-5503	7167-5525	28	125°
7167-5505	7167-5527	30	125°
7167-5507	7167-5529	32	125°
7167-5509	7167-5531	34	125°
7167-5511	7167-5533	36	125°
7167-5513	7167-5535	38	125°
7167-5515	7167-5537	40	125°
7167-5517	7167-5539	42	125°
7167-5519	7167-5541	44	125°
7167-5521	7167-5543	46	125°

Left	Right	Length	Neck Angle
7167-5502	7167-5524	26	130°
7167-5504	7167-5526	28	130°
7167-5506	7167-5528	30	130°
7167-5508	7167-5530	32	130°
7167-5510	7167-5532	34	130°
7167-5512	7167-5534	36	130°
7167-5514	7167-5536	38	130°
7167-5516	7167-5538	40	130°
7167-5518	7167-5540	42	130°
7167-5520	7167-5542	44	130°
7167-5522	7167-5544	46	130°

11.5mm Diameter Nails (26cm-46cm)
(Lime/Rose)

Left	Right	Length	Neck Angle
7167-6545	7167-6546	26	125°
7167-6547	7167-6548	28	125°
7167-6549	7167-6550	30	125°
7167-6551	7167-6552	32	125°
7167-6553	7167-6554	34	125°
7167-6555	7167-6556	36	125°
7167-6557	7167-6558	38	125°
7167-6559	7167-6560	40	125°
7167-6561	7167-6562	42	125°
7167-6563	7167-6564	44	125°
7167-6565	7167-6566	46	125°

Left	Right	Length	Neck Angle
7167-6567	7167-6568	26	130°
7167-6569	7167-6570	28	130°
7167-6571	7167-6572	30	130°
7167-6573	7167-6574	32	130°
7167-6575	7167-6576	34	130°
7167-6577	7167-6578	36	130°
7167-6579	7167-6580	38	130°
7167-6581	7167-6582	40	130°
7167-6583	7167-6584	42	130°
7167-6585	7167-6586	44	130°
7167-6587	7167-6588	46	130°

13mm Diameter Nails (26cm-46cm)
(Lime/Rose)

Left	Right	Length	Neck Angle
7167-6589	7167-6590	26	125°
7167-6591	7167-6592	28	125°
7167-6593	7167-6594	30	125°
7167-6595	7167-6596	32	125°
7167-6597	7167-6598	34	125°
7167-6599	7167-6600	36	125°
7167-6601	7167-6602	38	125°
7167-6603	7167-6604	40	125°
7167-6605	7167-6606	42	125°
7167-6607	7167-6608	44	125°
7167-6609	7167-6610	46	125°

Left	Right	Length	Neck Angle
7167-6611	7167-6612	26	130°
7167-6613	7167-6614	28	130°
7167-6615	7167-6616	30	130°
7167-6617	7167-6618	32	130°
7167-6619	7167-6620	34	130°
7167-6621	7167-6622	36	130°
7167-6623	7167-6624	38	130°
7167-6625	7167-6626	40	130°
7167-6627	7167-6628	42	130°
7167-6629	7167-6630	44	130°
7167-6631	7167-6632	46	130°

Smith & Nephew, Inc.
7135 Goodlett Farms Parkway
Cordova, TN 38016
USA

www.smith-nephew.com

Telephone: 1-901-396-2121
Information: 1-800-821-5700
Orders and Inquiries: 1-800-238-7538

°Trademark of Smith & Nephew. Certain marks Reg. US Pat. & TM Office.

©2014 Smith & Nephew, Inc.
All rights reserved.
01120 V1 71182195 REV0 05/14