

Table of Contents

Introduction.....	3
Product Overview	4
Surgical Technique	5
Patient Positioning.....	5
Reduce the Fracture	5
Approach.....	5
Plate Selection.....	6
Plate Placement.....	6
Calcar Hole Preparation.....	8
Intraoperative Compression with the Proximal Compression Handle	9
Superior Screw (7.5mm) Preparation.....	9
Superior Screw (7.5mm) Placement	10
Calcar Screw (8.5mm) Placement	10
4.5mm Shaft Screw Placement.....	11
Closure	12
Implant Removal.....	12
Appendix A: Alternative Technique without the Proximal Compression Handle.....	12
Catalog Information.....	14

Nota Bene

In the final analysis, the healthcare professional must exercise his or her own judgment in performing the procedure.

Introduction

The following technique is for informational and educational purposes only. It is not intended to serve as medical advice. It is the responsibility of treating physicians to determine and utilize the appropriate products and techniques, according to their own clinical judgment, for each of their patients. For more information on CONQUEST FN[®], including its indications for use, contraindications and product safety information, please refer to the product's label and the instructions for use packaged with the product.

Product Overview

CONQUEST FN[®] Femoral Neck Fracture System is a dynamic locking hip fracture fixation system. The system includes a comprehensive product offering dedicated to treating femoral neck fractures.

Proximal Femoral Locking Plate Design

The CONQUEST FN Locking Plates and washers are designed to provide both angle and length stability for hip preserving fixation. The proximal plates are anatomically designed for optimal guide pin placement and plate positioning.

- 125 degree neck angle
- Built in 14° of antiversión
- Three points of fixation in the neck and head - inverted triangle configuration
- 4.5mm locking and non-locking distal shaft screw fixation
- Superior and inferior provisional fixation slots



Proximal Telescoping Compression Screw Design - POGO*

The CONQUEST FN Proximal Screws are designed to provide postoperative reduction maintenance for hip preserving fixation. The integrated spring loaded POGO Screw applies constant fracture site compression ensuring bone on bone contact throughout the healing process.

Offering:

- 8.5mm and 7.5mm screw diameters
- Length range 75mm - 130mm x 5mm
- 10mm of controlled compression
- Cannulated for ease of implantation



Intuitive Instrumentation

Streamlined instrumentation allows for an easy flow of the surgical procedure. In addition, the Compression Handle and Tap aids fracture reduction maintenance to secure interfragmentary bony apposition while proximal screw insertion is performed.



*POGO[®] Screw is a licensed technology from FxDEVICES

Surgical Technique

Patient Positioning

Place the patient in the supine or lateral position on a radiolucent surgical table. Position the C-Arm to enable visualization of the proximal femur in both the AP and lateral planes.

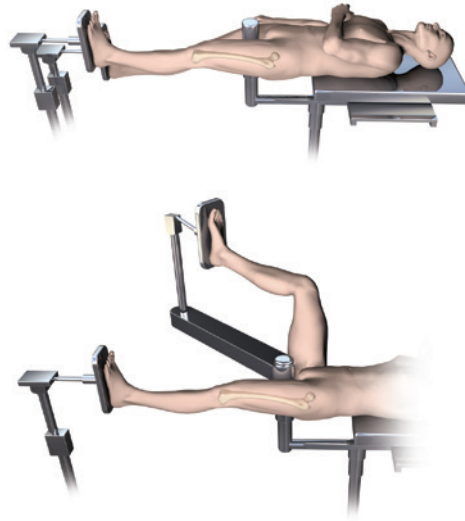

Reduce the Fracture

Reduce the fracture by means of traction/flexion, adduction/abduction and internal rotation. Verify fracture reduction in both planes using C-Arm. Open reduction should be considered if closed reduction is unsatisfactory.

Provisionally secure fracture fragments using 2.0mm K-wires or reduction forceps. Reduction aids should be placed so as not to interfere with final plate placement.

Approach

Make a straight skin incision starting on the posterior 1/3 of the proximal femur, two finger breaths posterior to straight mid-line on the iliotibial band.

Note: The CONQUEST FN[®] Plate is designed with 14° of anteversion of the Proximal Locking Screws. Therefore, a more posterior lateral incision is recommended to expose the proximal femur for ideal plate placement.

Plate Selection

Following fracture reduction, select the appropriate length CONQUEST FN® Plate that best accommodates patient anatomy and fracture pattern, or surgeon preference. Three hole, 2 hole, and 1 hole plates as well as 3 hole locking washers are available for both left and right femurs (Figure 1).



Figure 1

Plate Placement

1. Insert three 2.8mm Guide Pin Inserts (7117-9224) into three Proximal Locking Screw Drill Guides (7117-9203).
2. Using the 2-in-1 Hex Driver (7117-9201), attach the three drill guide assemblies to the CONQUEST FN Locking Plate (Figure 2). Attach the Plate Handle (7117-9204) for additional handling support (Figure 3).

Note: Proximal Locking Screw Drill Guide threads can be verified by using the thread checker in the inner tray.

3. Position the CONQUEST FN Locking Plate against the lateral aspect of the proximal femur. Extending distally, the plate will line up along the lateral cortex of the femoral shaft (Figure 4).



Figure 2

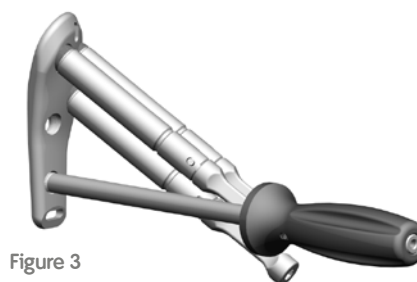

Figure 3

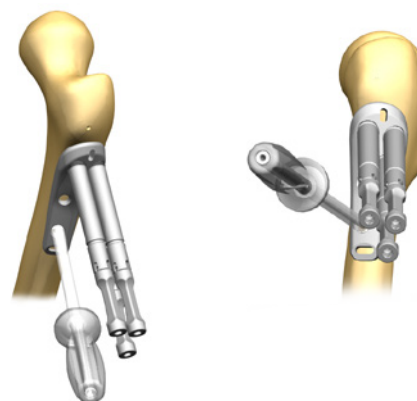

Figure 4

- Verify plate position inferior to the greater trochanter in both the AP and lateral views. Insert a 2.8mm Guide Pin (7117-9217) into the calcar through the 2.8mm Guide Pin Insert. Advance the 2.8mm Guide Pin to subcondylar bone, and verify the placement.

Optimal Guide Pin position is just superior to the calcar (AP view) (Figure 5a) and in the middle of the femoral neck and head (lateral view). (Figure 5b).

Note: The proximal screw holes are configured in an inverted triangle orientation. Once the calcar Guide Pin is placed in the ideal location, the remaining superior Guide Pins are placed parallel via the Drill Guide/Guide Pin Insert assemblies.

- To adjust or hold the position of the CONQUEST FN[®] Locking Plate on the shaft of the femur, the following options are available:
 - Remove the calcar 2.8mm Guide Pin Insert and insert the Parallel Pin Guide (7117-9226) over the inserted 2.8mm Guide Pin (Figure 6a). Rotate the Parallel Pin Guide and insert a second 2.8mm Guide Pin through the second hole in the desired calcar location (Figure 6b). Remove the original 2.8mm Guide Pin and the Parallel Pin Guide. Reinsert the 2.8mm Guide Pin Insert over the adjusted 2.8mm Guide Pin.
 - Insert a 2.0mm K-Wire (7116-1020) or 3.5mm x 18mm PF Pin (7117-3324) through the proximal provisional fixation slot to hold the plate position in the lateral plane and adjust in the AP plane (Figure 6c).
 - Insert a 2.0mm K-Wire or 3.5mm x 18mm PF Pin through the distal provisional fixation slot to hold the plate position in the AP plane and adjust in the lateral plane (Figure 6d).
 - Insert a 3.5mm x 18mm PF Pin or a PERI-LOC[®] 4.5mm Screw through a shaft screw hole (Figure 6e).
 - Insert a 2.8mm Guide Pin through the Plate Handle (Figure 6f).

Note: Initial insertion of provisional fixation pins may be started under power, but final seating must be performed by hand to avoid stripping of the threads and loss of purchase.

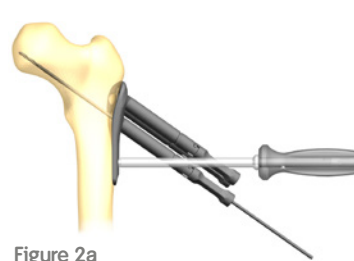

Figure 2a

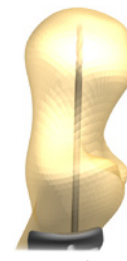

Figure 5b

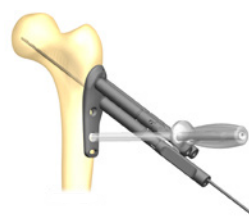

Figure 3a

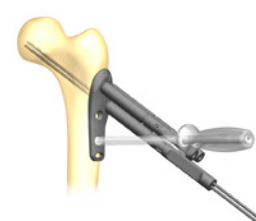

Figure 6b

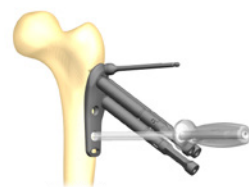

Figure 6c

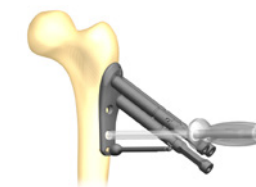

Figure 6d

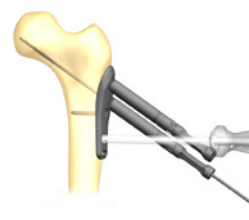

Figure 6e

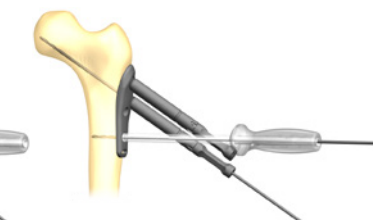

Figure 6f

-
6. Insert the superior 2.8mm Guide Pins and verify placement with a C-Arm. Ensure all three 2.8mm Guide Pins are parallel in the AP (Figure 7a) and lateral (Figure 7b) planes.

Note: If only two screws will fit in the femoral neck, use the calcar and anterior-superior screw holes.

Note: CONQUEST FN® Proximal Locking Screws are not self-drilling or self-tapping. The Proximal Taps must be used prior to screw insertion.

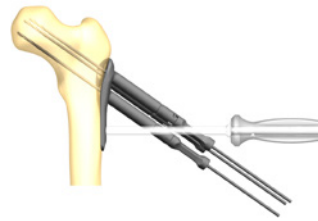

Figure 4a



Figure 7b

Calcar Hole Preparation

7. Measure for drill depth by reading the calibrations on the 2.8mm Guide Pin against the 2.8mm Guide Pin Insert or use the Proximal Screw Depth Gauge (7117-9225) (Figure 8).

Note: The measurement of the Guide Pin corresponds to the Proximal Screw length at its fully extended position.

8. Remove the calcar 2.8mm Guide Pin Insert from the Proximal Locking Screw Drill Guide. Drill over the 2.8mm Guide Pin with the Proximal Drill (7117-9208) (Figure 9).
9. Measure for Proximal Screw length by reading the calibrations on the Proximal Drill against the Proximal Locking Screw Drill Guide. Take C-Arm shots to verify final Proximal Drill location.
10. Remove the Proximal Drill.

Note: Use the Obturator (7175-1145) to help maintain the Guide Pin position in the bone.

11. Tap using the Proximal Screw Tap - Compression (7117-9219) with the Screwdriver Handle (7117-9213) (Figure 10).

Note: Do not remove the Proximal Screw Tap - Compression. The tap will be used as an anti-rotation device for superior screw placement.

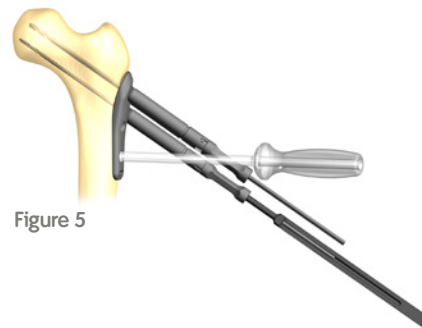

Figure 5

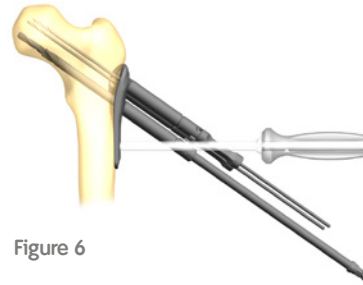

Figure 6

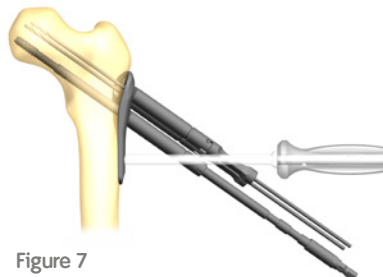

Figure 7

Intraoperative Compression with the Proximal Compression Handle

If the Proximal Compression Handle is not utilized, refer to Appendix A.

12. With the Proximal Compression Handle (7117-9218) completely collapsed, align the tabs with the grooves of the Proximal Screw Tap - Compression (Figure 11a).
13. Attach the Proximal Compression Handle to the fully inserted Proximal Screw Tap - Compression.
14. Using your thumb, push the end of the ratchet bar of the Proximal Compression Handle until the medial tab fully seats against the end of the Proximal Locking Screw Drill Guide (Figure 11b).
15. Squeeze the trigger of the Proximal Compression Handle until desired compression is achieved. Confirm desired fracture gap compression with a C-Arm.

Note: One click for the Proximal Compression Handle is equivalent to 1mm of compression.

Note: To prevent the Proximal Screw Tap - Compression from stripping out of the femoral head, care should be taken while compressing. Take C-Arm shots to confirm desired fracture gap compression.

Note: Do not remove the Proximal Compression Handle from the Proximal Screw Tap - Compression. This assembly will aid in maintaining fracture reduction for superior screw insertion.

Superior Screw (7.5mm) Preparation

16. Measure for drill depth by reading the calibrations on the 2.8mm Guide Pin against the 2.8mm Guide Pin Insert or use the Proximal Screw Depth Gauge of desired superior screw hole (Figure 12).
17. Remove the 2.8mm Guide Pin Insert from the Proximal Locking Screw Drill Guide and drill over the 2.8mm Guide Pin with the Proximal Drill. (Figure 13).
18. Measure for Proximal Screw length by reading the calibrations on the Proximal Drill against the Proximal Locking Screw Drill Guide. Take C-Arm shots to verify desired location. Remove the Proximal Drill.

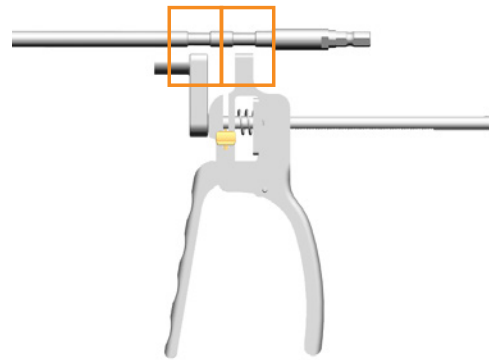

Figure 8a

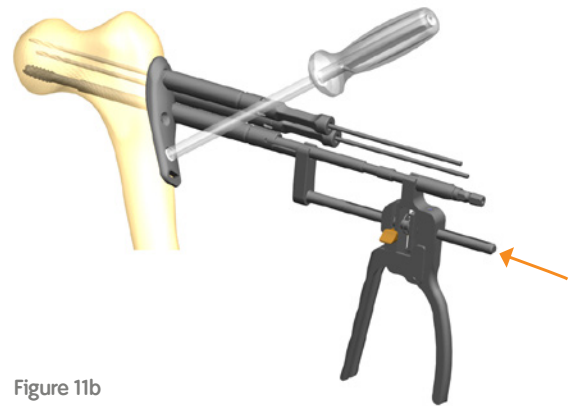

Figure 11b

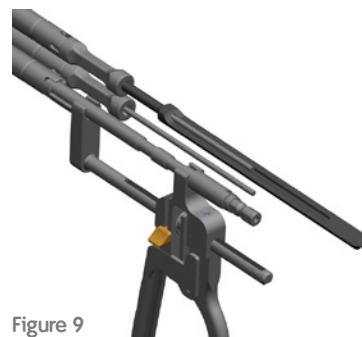

Figure 9



Figure 10

-
19. Tap using the Proximal Screw Tap (7117-9231) with the Screwdriver Handle. Measure for Proximal Screw length by reading the calibrations on the Proximal Tap against the Proximal Locking Screw Drill Guide. Take C-Arm shots to verify desired location (Figure 14). Remove the Proximal Tap.
 20. Remove the Proximal Locking Screw Drill Guide using the 2-in-1 Hex Driver - 4.7mm.



Figure 11

Superior Screw (7.5mm) Placement

21. Attach a 7.5mm Proximal Locking Screw to the Proximal Screwdriver (7117-9215). Retain and extend the Proximal Locking Screw using the Proximal Screw Extension Rod (Figure 15).



Figure 12

Note: Attach the Proximal Screwdriver to the Proximal Screw before inserting the Screw Extension Rod. The screwdriver will not engage the screw if the Screw Extension Rod is already inserted past the black line as shown in Figure 15.

Note: Screw length and diameter can be verified by using the screw gauge in the inner tray.

22. Insert the 7.5mm Proximal Locking Screw by hand over the 2.8mm Guide Pin using the Screwdriver Handle. Verify the Proximal Locking Screw position with a C-Arm.

Note: To remove the Proximal Screwdriver from the CONQUEST FN[®] Proximal Locking Screws, unthread the Screw Extension Rod from the Proximal Screwdriver and pull the Screw Extension Rod out of the Proximal Screwdriver.

23. Repeat steps to place the remaining superior screw.

Calcar Screw (8.5mm) Placement

24. Following Superior Screw Insertion, measure for calcar Proximal Screw length by reading the calibrations on the Proximal Screw Tap - Compression against the back of the Proximal Locking Screw Drill Guide (Figure 16). This measurement corresponds to the 8.5mm Proximal Screw length.



Figure 13

25. Remove the Proximal Compression Handle and Proximal Screw Tap - Compression assembly by attaching the Screwdriver Handle to the Proximal Screw Tap - Compression and reverse by hand.
26. Attach the 8.5mm Proximal Locking Screw to the Proximal Screwdriver. Retain and extend the Proximal Locking Screw using the Proximal Screw Extension Rod (Figure 17).
27. Insert the 8.5mm Proximal Locking Screw by hand over the 2.8mm Guide Pin using the Screwdriver Handle (Figure 18).
28. Verify all Proximal Locking Screw positions with a C-Arm.



Figure 14

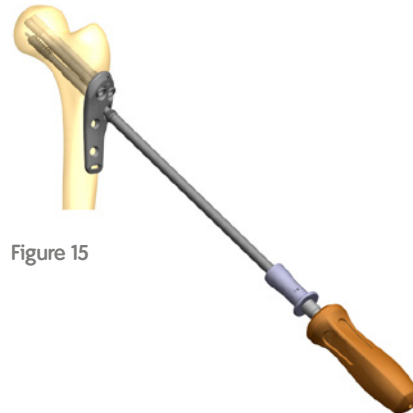

Figure 15

4.5mm Shaft Screw Placement

Non-Locking Screws

29. Insert the Universal Handle (7117-7203) with the 3.5mm Neutral Locking Hole Insert (7117-3521) into the desired screw hole and drill with the Standard 3.5mm Drill (7117-3505). Measure for screw length by reading the calibrations on the 3.5mm Drill Bit against the 3.5mm Neutral Locking Hole Insert (7117-3521) or measure for screw length by reading the calibrations on the Large Fragment Depth Gauge (7117-3331).
30. Insert the appropriate length 4.5mm Non-Locking Screw using the Self-Retaining Screwdriver (7117-3616) and Tear Drop Handle (7117-3543) (Figure 19).

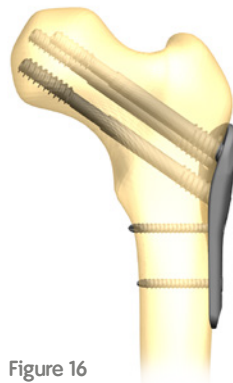

Figure 16

Locking Screws

31. Thread a 3.5mm Locking Drill Guide, (7117-3451) into the desired screw hole (tighten using the 2-in-1 Hex Driver - 4.7mm) and drill with the Standard 3.5mm Drill Bit. Measure for screw length by reading the calibrations on the 3.5mm Drill Bit against the 3.5mm Locking Drill Guide or measure for screw length by reading the calibrations on Large Fragment Depth Gauge.
32. Remove the 3.5mm Locking Drill Guide.
33. Insert the appropriate length 4.5mm Locking Screw using the Self-Retaining Screwdriver and Tear Drop Handle (Figure 19).

Closure

34. Remove all remaining provisional fixation devices.
 35. Obtain final AP and lateral radiographic images to confirm patient implant position and fracture reduction.
 36. Wound closure follows standard technique.
-

Implant Removal

37. Expose the implant construct by making an incision on the proximal portion of the lateral femur.
38. Assemble the Proximal Screwdriver and Screw Extension Rod to the Proximal Screw. By hand, remove the Proximal Screws from the plate.

Note: Ensure the Proximal Screwdriver is engaged with the Proximal Screw prior to inserting the Screw Extension Rod.

Note: In case of Proximal Screw collapse, the Screw Extension Rod may not thread into the Proximal Screwdriver.

39. If the Proximal Screwdriver and Screw Extension Rod are not available, an appropriate size blade screwdriver or osteotome can be placed into the hex.

Note: When using an alternate device, the CONQUEST FN[®] Proximal Locking Screws will not appear to be backing out until the spring has fully compressed.

Appendix A: Alternative Technique without the Proximal Compression Handle

Superior Screw (7.5mm) Placement

12. Measure for drill depth by reading the calibrations on the 2.8mm Guide Pin against the 2.8mm Guide Pin Insert or Proximal Screw Depth Gauge of desired superior screw hole (Figure 20).
13. Remove the 2.8mm Guide Pin Insert from the Proximal Locking Screw Drill Guide and drill over the 2.8mm Guide Pin with the Proximal Drill (Figure 21).



Figure 17

14. Measure for Proximal Screw length by reading the calibrations on the Proximal Drill against the Proximal Locking Screw Drill Guide. Take C-Arm shots to verify final Proximal Drill location.
15. Remove the Proximal Drill.

Note: Use the Obturator (7175-1145) to help maintain the Guide Pin position in the bone.

16. Tap using the Proximal Screw Tap (7117-9231). Measure for proximal screw length by reading the calibrations on the Proximal Tap against the Proximal Locking Screw Drill Guide. Take C-Arm shots to verify desired location (Figure 22).

17. Remove the Proximal Tap

18. Remove the Proximal Locking Screw Drill Guide using the 2-in-1 Hex Driver - 4.7mm.

19. Attach a 7.5mm Proximal Locking Screw to the Proximal Screwdriver (7117-9215). Retain the Proximal Locking screw using the Proximal Screw Extension Rod (Figure 23).

Note: Attach the Proximal Screwdriver to the Proximal Screw before inserting the Extension Rod. The Screwdriver will not engage the screw if the Extension Rod is already inserted past the black line as shown in Figure 23.

20. Insert the 7.5mm Proximal Locking Screw by hand over the 2.8mm Guide Pin using the Screwdriver Handle (Figure 24). Verify the Proximal Locking Screw position with a C-Arm.

Note: To remove the Proximal Screwdriver from the CONQUEST FN[®] Proximal Locking Screws, unthread the Screw Extension Rod from the Proximal Screwdriver and pull the Screw Extension Rod out of the Proximal Screwdriver.

21. Repeat steps to place a second superior screw.

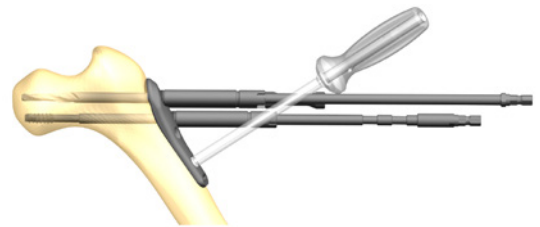

Figure 18



Figure 19



Figure 20

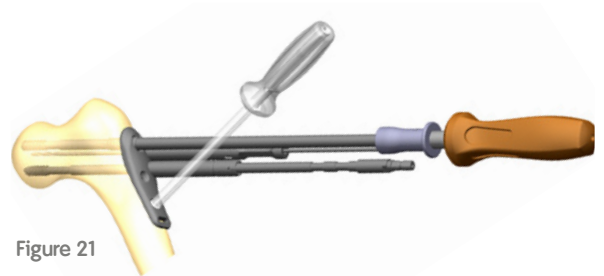

Figure 21

Calcar Screw (8.5mm) Placement

22. Attach the Screwdriver Handle to the Proximal Tap – Compression and remove the Tap.
23. Remove the Proximal Locking Screw Drill Guide using the 2-in-1 Hex Driver - 4.7mm.
24. Attach an 8.5mm Proximal Locking Screw to the Proximal Screwdriver. Retain the Proximal Locking screw using the Proximal Screw Extension Rod (Figure 25).
25. Insert the 8.5mm Proximal Locking Screw by hand over the 2.8mm Guide Pin using the Screwdriver Handle (Figure 26).
26. Verify all Proximal Locking Screw positions with a C-Arm.



Figure 22

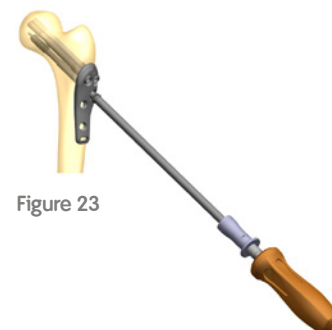
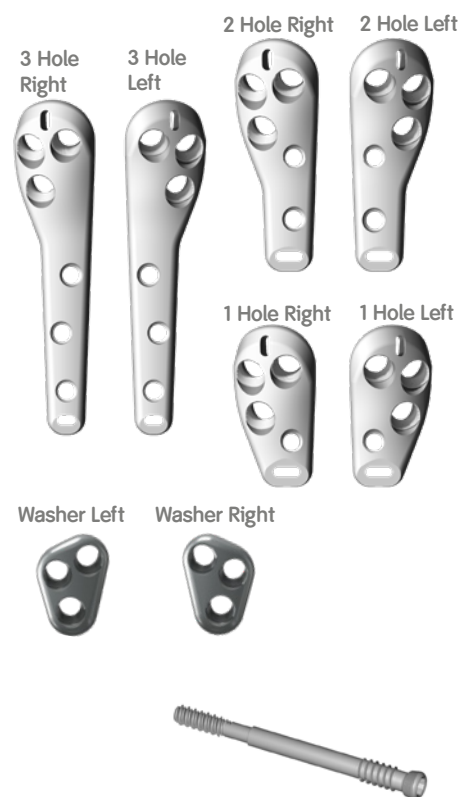

Figure 23

Catalog Information

Cat. Item	Description	Qty
CONQUEST FN® Locking Washers – Set No. 7181-1417		
7580-8000L	CONQUEST FN Locking Washer Left	1
7580-8000R	CONQUEST FN Locking Washer Right	1
CONQUEST FN® Locking Plates 60mm – Set No. 7181-1409		
7580-8001L	CONQUEST FN Locking Plate 1H Left 60mm	1
7580-8001R	CONQUEST FN Locking Plate 1H Right 60mm	1
CONQUEST FN Locking Plates 85mm – Set No. 7181-1409		
7580-8002L	CONQUEST FN Locking Plate 2H Left 85mm	1
7580-8002R	CONQUEST FN Locking Plate 2H Right 85mm	1
CONQUEST FN Locking Plates 127mm		
7580-8003L*	CONQUEST FN Locking Plate 3H Left 127mm	1
7580-8003R*	CONQUEST FN Locking Plate 3H Right 127mm	1
CONQUEST FN 7.5mm Proximal Locking Screws SS – Set No. 7181-1411		
7580-7075	CONQUEST FN 7.5mm x 75mm Proximal Locking Screw SS	2
7580-7080	CONQUEST FN 7.5mm x 80mm Proximal Locking Screw SS	2
7580-7085	CONQUEST FN 7.5mm x 85mm Proximal Locking Screw SS	2
7580-7090	CONQUEST FN 7.5mm x 90mm Proximal Locking Screw SS	2
7580-7095	CONQUEST FN 7.5mm x 95mm Proximal Locking Screw SS	2
7580-7200	CONQUEST FN 7.5mm x 100mm Proximal Locking Screw SS	2
7580-7205	CONQUEST FN 7.5mm x 105mm Proximal Locking Screw SS	2
7580-7210	CONQUEST FN 7.5mm x 110mm Proximal Locking Screw SS	2
7580-7215	CONQUEST FN 7.5mm x 115mm Proximal Locking Screw SS	2
7580-7220*	CONQUEST FN 7.5mm x 120mm Proximal Locking Screw SS	0
7580-7225*	CONQUEST FN 7.5mm x 125mm Proximal Locking Screw SS	0
7580-7230*	CONQUEST FN 7.5mm x 130mm Proximal Locking Screw SS	0
CONQUEST FN 8.5mm Proximal Locking Screws SS – Set No. 7181-1412		
7580-8075	CONQUEST FN 8.5mm x 75mm Proximal Locking Screw SS	1
7580-8080	CONQUEST FN 8.5mm x 80mm Proximal Locking Screw SS	1
7580-8085	CONQUEST FN 8.5mm x 85mm Proximal Locking Screw SS	1
7580-8090	CONQUEST FN 8.5mm x 90mm Proximal Locking Screw SS	1
7580-8095	CONQUEST FN 8.5mm x 95mm Proximal Locking Screw SS	1
7580-8200	CONQUEST FN 8.5mm x 100mm Proximal Locking Screw SS	1
7580-8205	CONQUEST FN 8.5mm x 105mm Proximal Locking Screw SS	1
7580-8210	CONQUEST FN 8.5mm x 110mm Proximal Locking Screw SS	1
7580-8215	CONQUEST FN 8.5mm x 115mm Proximal Locking Screw SS	1
7580-8220*	CONQUEST FN 8.5mm x 120mm Proximal Locking Screw SS	0
7580-8225*	CONQUEST FN 8.5mm x 125mm Proximal Locking Screw SS	0
7580-8230*	CONQUEST FN 8.5mm x 130mm Proximal Locking Screw SS	0
CONQUEST FN Samples		
7119-0107	CONQUEST FN 7.5mm x 95mm Proximal Locking Screw SS Sample	
7119-0108	CONQUEST FN 8.5mm x 95mm Proximal Locking Screw SS Sample	
7119-0112	CONQUEST FN Locking Plate 2H Left 85mm Sample	
7119-0113	CONQUEST FN Locking Washer Left Sample	



*Available sterile - order separately. Quantities marked 0 are available to order separately.

Cat. Item	Description	Qty
PERI-LOC® 4.5mm T25 Locking Screw S-T – Set No. 7181-1403		
7380-7028	PERI-LOC 4.5mm T25 Lock Screw 28mm S-T	1
7380-7030	PERI-LOC 4.5mm T25 Lock Screw 30mm S-T	1
7380-7032	PERI-LOC 4.5mm T25 Lock Screw 32mm S-T	1
7380-7034	PERI-LOC 4.5mm T25 Lock Screw 34mm S-T	1
7380-7036	PERI-LOC 4.5mm T25 Lock Screw 36mm S-T	1
7380-7038	PERI-LOC 4.5mm T25 Lock Screw 38mm S-T	1
7380-7040	PERI-LOC 4.5mm T25 Lock Screw 40mm S-T	1
7380-7042	PERI-LOC 4.5mm T25 Lock Screw 42mm S-T	1
7380-7044	PERI-LOC 4.5mm T25 Lock Screw 44mm S-T	1
PERI-LOC 4.5mm T25 Crtx Screw S-T – Set No. 7181-1400		
7380-6028	PERI-LOC 4.5mm T25 Crtx Screw 28mm S-T	1
7380-6030	PERI-LOC 4.5mm T25 Crtx Screw 30mm S-T	1
7380-6032	PERI-LOC 4.5mm T25 Crtx Screw 32mm S-T	1
7380-6034	PERI-LOC 4.5mm T25 Crtx Screw 34mm S-T	1
7380-6036	PERI-LOC 4.5mm T25 Crtx Screw 36mm S-T	1
7380-6038	PERI-LOC 4.5mm T25 Crtx Screw 38mm S-T	1
7380-6040	PERI-LOC 4.5mm T25 Crtx Screw 40mm S-T	1
7380-6042	PERI-LOC 4.5mm T25 Crtx Screw 42mm S-T	1
7380-6044	PERI-LOC 4.5mm T25 Crtx Screw 44mm S-T	1
CONQUEST FN® Disposable Set – Set No. 7181-1405		
7117-9217	2.8mm x 300mm Drill Tip Guide Pin	6
7116-1020	PERI-LOC K-Wire 2.0mm x 150mm Length 6 Trocar Point	6
7117-3324	3.5mm PF Pin 18mm	2
7117-3505	3.5mm Drill Bit w/AO Quick Connect	1
7117-9208	CONQUEST FN Proximal Drill	1
7117-9219	CONQUEST FN Proximal Screw Tap - Compression	1
7117-9231	CONQUEST FN Proximal Screw Tap	1
7117-9216	CONQUEST FN Screw Extension Rod	1
CONQUEST FN® Instrument Set – Set No. 7181-1404		
7117-9201	CONQUEST FN 2-in-1 Hex Driver – 4.7mm	1
7117-9224	CONQUEST FN 2.8mm Guide Pin Insert	3
7117-9226	CONQUEST FN Parallel Pin Guide - 4.0mm Offset	1
7117-9203	CONQUEST FN Proximal Locking Screw Drill Guide	3
7117-9204	CONQUEST FN Plate Handle	1
7117-9225	CONQUEST FN Proximal Screw Depth Gauge	1
7117-9213	Screwdriver Handle - Large	1
7117-9215	CONQUEST FN Screwdriver	1
7106-3004	AO To Hall Adapter	1
7117-7203	Universal Drill Guide Handle	1
7117-3521	3.5mm Neutral Locking Hole Insert	1
7117-3451	3.5mm Locking Drill Guide	1
7117-3331	Large Fragment Depth Gauge	1
7117-3543	Tear Drop Screwdriver Handle	1
7117-3616	T25 Self-Ret Screwdriver Shaft w/QC 178mm	1
7175-1145	Obturator	1
7117-9218	CONQUEST FN Proximal Compression Handle	1
7117-9227	CONQUEST FN Inner Tray	1
7117-9228	CONQUEST FN Tray	1
7117-9222	CONQUEST FN Tray Lid	1

Supporting healthcare professionals for over 150 years

Smith & Nephew, Inc.
1450 Brooks Road
Memphis, TN 38116
USA

www.smith-nephew.com

Telephone: 1-901-396-2121
Information: 1-800-821-5700
Orders/Inquiries: 1-800-238-7538

©2018 Smith & Nephew.
03339 V4 71182200 REVC 01/20

°Trademark of Smith & Nephew.